

Service Manual



SD-24 TDR/Sampling Head

070-7053-01

Warning

The servicing instructions are for use by qualified personnel only. To avoid personal injury, do not perform any servicing unless you are qualified to do so. Refer to the Safety Summary prior to performing service.

Please check for change information at the rear of this manual.

First Printing: May 1993

Instrument Serial Numbers

Each instrument manufactured by Tektronix has a serial number on a panel insert or tag, or stamped on the chassis. The first letter in the serial number designates the country of manufacture. The last five digits of the serial number are assigned sequentially and are unique to each instrument. Those manufactured in the United States have six unique digits. The country of manufacture is identified as follows:

B010000	Tektronix, Inc., Beaverton, Oregon, USA
E200000	Tektronix United Kingdom, Ltd., London
J300000	Sony/Tektronix, Japan
H700000	Tektronix Holland, NV, Heerenveen, The Netherlands

Instruments manufactured for Tektronix by external vendors outside the United States are assigned a two digit alpha code to identify the country of manufacture (e.g., JP for Japan, HK for Hong Kong, IL for Israel, etc.).

Tektronix, Inc., P.O. Box 500, Beaverton, OR 97077

Printed in U.S.A.

Copyright © Tektronix, Inc., 1988, 1993. All rights reserved. Tektronix products are covered by U.S. and foreign patents, issued and pending. The following are registered trademarks: TEKTRONIX, TEK, TEKPROBE, and SCOPE-MOBILE.

WARRANTY

Tektronix warrants that this product will be free from defects in materials and workmanship for a period of one (1) year from the date of shipment. If any such product proves defective during this warranty period, Tektronix, at its option, either will repair the defective product without charge for parts and labor, or will provide a replacement in exchange for the defective product.

In order to obtain service under this warranty, Customer must notify Tektronix of the defect before the expiration of the warranty period and make suitable arrangements for the performance of service. Customer shall be responsible for packaging and shipping the defective product to the service center designated by Tektronix, with shipping charges prepaid. Tektronix shall pay for the return of the product to Customer if the shipment is to a location within the country in which the Tektronix service center is located. Customer shall be responsible for paying all shipping charges, duties, taxes, and any other charges for products returned to any other locations.

This warranty shall not apply to any defect, failure or damage caused by improper use or improper or inadequate maintenance and care. Tektronix shall not be obligated to furnish service under this warranty a) to repair damage resulting from attempts by personnel other than Tektronix representatives to install, repair or service the product; b) to repair damage resulting from improper use or connection to incompatible equipment; or c) to service a product that has been modified or integrated with other products when the effect of such modification or integration increases the time or difficulty of servicing the product.

THIS WARRANTY IS GIVEN BY TEKTRONIX WITH RESPECT TO THIS PRODUCT IN LIEU OF ANY OTHER WARRANTIES, EXPRESSED OR IMPLIED. TEKTRONIX AND ITS VENDORS DISCLAIM ANY IMPLIED WARRANTIES OF MERCHANTABILITY OR FITNESS FOR A PARTICULAR PURPOSE. TEKTRONIX' RESPONSIBILITY TO REPAIR OR REPLACE DEFECTIVE PRODUCTS IS THE SOLE AND EXCLUSIVE REMEDY PROVIDED TO THE CUSTOMER FOR BREACH OF THIS WARRANTY. TEKTRONIX AND ITS VENDORS WILL NOT BE LIABLE FOR ANY INDIRECT, SPECIAL, INCIDENTAL, OR CONSEQUENTIAL DAMAGES IRRESPECTIVE OF WHETHER TEKTRONIX OR THE VENDOR HAS ADVANCE NOTICE OF THE POSSIBILITY OF SUCH DAMAGES.

Table of Contents

List of Figures	iii
List of Tables	v

General Information

General Information	1-1
Introduction	1-1
Safety Summary	1-2
Installing and Removing the Sampling Head	1-4
Packaging for Shipment	1-6
Operating Environment	1-7
Operating Temperature	1-7

Checks and Adjustments

Checks and Adjustments	2-1
Test Equipment	2-3
Using These Procedures	2-5
Conventions in this Manual	2-5
Initialized and Stored Settings	2-5
Menu Selections and Measurement Techniques	2-5
Setup Illustrations	2-6
Part 1 Power-On	2-8
Part 2 Dot Transient Response	2-10
Part 3 Offset	2-15
Part 4 Noise	2-19
Part 5 Rise Time	2-22
Part 6 Acquisition Aberrations	2-25
Part 7 Coincidence Between Channels	2-29
Part 8 Maximum Signal Voltage	2-32
Part 9 Isolation Between Channels	2-35
Part 10 Output Amplitude	2-38
Part 11 TDR Aberrations	2-40
Part 12 Reflected Rise Time	2-44

Maintenance

Maintenance	3-1
Preventive Maintenance	3-1
Exterior	3-1
Periodic Electrical Checks	3-1
Static-Sensitive Device Classification	3-2
Exchanging Sampling Heads	3-4
Removing and Replacing the Sampling Head Internal Circuitry	3-4
Changing the Sampling Head Identification Number	3-6

Theory of Operation

Theory of Operation	4-1
System Functional Overview	4-2
TDR Step Generation	4-3
Operation With a Short Circuit	4-3
Operation With a 50 Ω Load	4-4
Operation With an Open Circuit	4-4
TDR Amplitude	4-5
Loop Gain	4-6
Offset Null	4-7

Replaceable Parts

Replaceable Parts	5-1
Parts Ordering Information	5-1
Using the Replaceable Parts List	5-2

List of Figures

Figure 1-1: Sampling Head Compartments in an 11801B and a
CSA 803A 1-4

Figure 1-2: Installing a Sampling Head In An Instrument 1-5

Figure 2-1: Locations of Controls and Connectors on Mainframe
Instruments 2-7

Figure 3-1: Sampling Head Screw Locations 3-5

Figure 3-2: A5 Time Base/Controller Board Jumper Location 3-6

Figure 4-1: SD-24 TDR/Sampling Head Block Diagram 4-2

Figure 4-2: Step Generator Simplified Schematic Diagram 4-3

Figure 4-3: Step Generator With a Shorted Output 4-3

Figure 4-4: Step Generation With a 50 Ω Load 4-4

Figure 4-5: Step Generation With an Open Circuit 4-4

Figure 4-6: Displayed Trace With Three Loop Gain Settings 4-6

Figure 5-1: Exploded View of the SD-24 Sampling Head 5-5

List of Figures

List of Tables

Table 2-1: Measurement Limits and Specifications	2-1
Table 2-2: Test Equipment	2-3
Table 2-3: Acquisition Aberration Specifications	2-25
Table 2-4: TDR Aberration Specifications	2-40
Table 3-1: Relative Susceptibility to Electrostatic Discharge (ESD) ..	3-3

List of Tables

General Information

This section gives all the information needed to apply power to the SD-24 TDR/Sampling Head.

Safety information as well as information on installing and removing the sampling head, packaging for shipment, and environmental conditions such as operating temperature is included here.

Introduction

The *SD-24 TDR/Sampling Head Service Manual* is designed for use by qualified service personnel. It contains information necessary to check and maintain the SD-24 TDR/Sampling Head.

The SD-24 TDR/Sampling Head is a two-channel, 17.5 ps rise time sampling head. Each channel is also capable of generating its own TDR output pulse. The SD-24 TDR/Sampling Head is designed for use in 11800 Series Digital Sampling Oscilloscopes, the SM-11 Multi-Channel Unit, and the CSA 803 Series Communications Signal Analyzers.

Safety Summary

The safety information in this part of the summary is for both operating and servicing personnel. Specific warnings and cautions will be found throughout the manual where they apply, but may not appear in this summary.

Terms in Manuals

CAUTION statements in manuals identify conditions or practices that could result in damage to the equipment or other property.

WARNING statements in manuals identify conditions or practices that could result in personal injury or loss of life.

Terms on Equipment

CAUTION on equipment means a personal injury hazard not immediately accessible as one reads the marking, or a hazard to property including the equipment itself.

DANGER on equipment means a personal injury hazard immediately accessible as one reads the marking.

Symbols in Manuals



Static Sensitive Devices

Symbols on Equipment



DANGER
High Voltage



Protective
ground (earth)
terminal



ATTENTION
Refer to
manual

Grounding the Instrument

This sampling head is grounded through the grounding conductor of the oscilloscope's power cord. To avoid electric shock, plug the power cord into a properly wired receptacle before connecting to the product input or output terminal. A protective-ground connection, by way of the grounding conductor in the power cord, is essential for safe operation.

Danger Arising from Loss of Ground

Upon loss of the protective-ground connection, all accessible conductive parts (including knobs and controls that may appear to be insulating), can render an electric shock.

Do Not Operate in Explosive Atmospheres

To avoid explosion, do not operate the sampling head in an atmosphere of explosive gasses.

Installing and Removing the Sampling Head

The SD-24 TDR/Sampling Head slides into the one of the front panel compartments of the 11800 Series or CSA 803 Series instruments. Figure 1-1 shows the front panels of the instrument mainframe and the locations of the sampling head compartments.

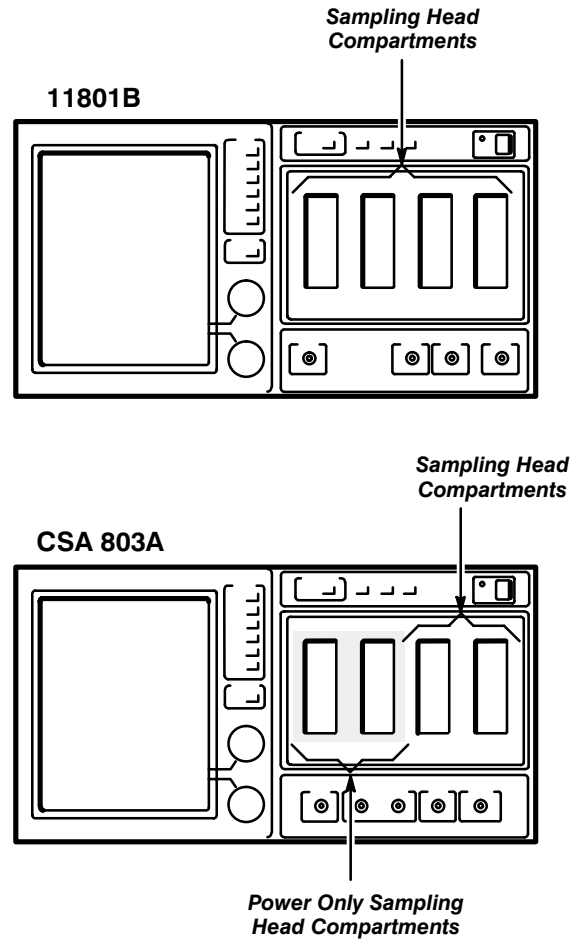

Figure 1-1: Sampling Head Compartments in an 11801B and a CSA 803A

With the ON/STANDBY switch set to STANDBY, place the sampling head in a compartment and slowly push it in with firm pressure. Once the sampling head is seated, turn the lock-down screw to tighten the sampling head in place. See Figure 1-2.



To avoid damage to the instrument, set the instrument's ON/STANDBY switch to STANDBY before installing or removing a sampling head.

If the green indicator light remains on when the STANDBY position is selected, then the switch has been left internally disabled after the servicing of the power supply. To enable the ON/STANDBY switch, refer to the Maintenance section of your instrument's Service Manual.

To remove the sampling head from an instrument, set the instrument's ON/STANDBY switch to STANDBY. Turn the lock-down screw to loosen the sampling head, and then slowly pull out the sampling head.

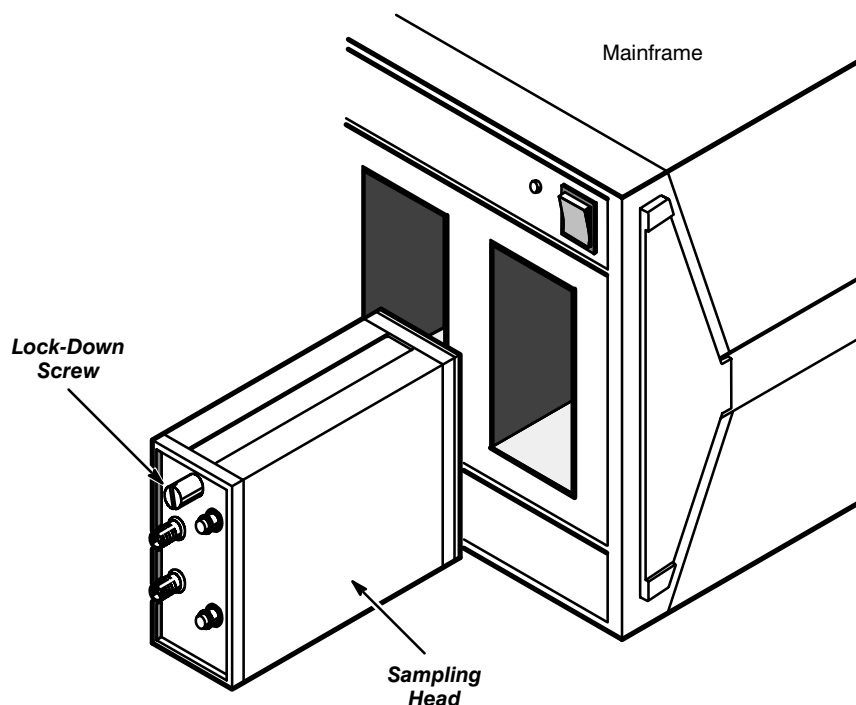

Figure 1-2: Installing a Sampling Head In An Instrument

Packaging for Shipment

If possible, save and reuse the original carton and packaging to package sampling head when shipping it by commercial transportation.

Attach a tag to the sampling head if it is shipped to your local Tektronix Service Center for service or repair. Include the following information on the tag:

- Name and address of the instrument and sampling head owner
- Name of a person at your firm who can be contacted about the instrument and sampling head
- Complete instrument and sampling head type and serial number
- A description of the service required

Package the sampling head as follows, if the original package is not available or is not fit for use:

- Step 1:** Attach short circuit terminations to the sampling head inputs.
- Step 2:** Obtain a corrugated cardboard carton with inside dimensions at least six inches (15 cm) greater than the sampling head dimensions. Use a carton with a bursting test strength of at least 200 pounds per square-inch.
- Step 3:** Fully wrap the sampling head with anti-static sheeting, or its equivalent, to protect the finish.
- Step 4:** Tightly pack dunnage or urethane foam between the carton and the sampling head to cushion the sampling head on all sides. Allow three inches of packing on each side.
- Step 5:** Seal the carton with shipping tape or with industrial staples.
- Step 6:** Mark the address of the Tektronix Service Center and your return address on the carton in one or more prominent places.

Operating Environment

The following environmental requirements are provided to ensure proper operation and long sampling head life.

Operating Temperature

Operate the sampling head where the ambient temperature is between 0° C and +50° C. Store the sampling head in ambient temperatures from –40° C to +75° C. After storage at temperatures outside the operating limits, allow the chassis to reach the operating temperature range before applying power.

Allow a 20 minute warmup before performing the calibrations in the Enhanced Accuracy menu of the instrument mainframe. Calibrations should be repeated if the temperature changes more than $\pm 5^{\circ}$ C or if the sampling head is removed from the instrument.

Checks and Adjustments

This section contains procedures to check the specifications and measurement limits listed in Table 2-1. The Specification or Measurement Limit is listed at the beginning of each part as well. These procedures contain only check steps since the SD-24 TDR/Sampling Head has no internal adjustments.

The procedures in this section provide a logical sequence of checks for performing a comprehensive performance verification procedure to verify that the sampling head meets specifications. To functionally test the sampling head, perform the parts in Table 2-1 which have a “yes” indication in the Functional Test Column.

Refer to the *SD-24 TDR/Sampling Head User Manual* for more information about specifications and sampling head operation. Refer to Table 2-2 for information concerning test equipment used in the setups.

Table 2-1: Measurement Limits and Specifications

Part and Description	Measurement Limit	Specification	Functional Test
Part 1 Power-On	none	none	yes
Part 2 Dot Transient Response			
250 mV with automatic calibration	≤ 5% error		yes
500 mV with automatic calibration	≤ 5% error		no
500 mV with default settings	± 20% error		no
1.0 V without automatic calibration		adjusted to 100% at 1 V	no
Part 3 Offset			
Offset	± 2 mV		yes
Offset change with repetition rate		± 5 mV	no

Table 2-1: Measurement Limits and Specifications (Cont.)

Part and Description	Measurement Limit	Specification	Functional Test
Part 4 Noise (SN B020652 and above)			no
Smoothing, on	$\leq 550 \mu\text{V}_{\text{RMS}}$		
Smoothing, off	$\leq 1.2 \text{ mV}_{\text{RMS}}$		
Part 4 Noise (SN B010651 and below)			no
Smoothing, on	$\leq 900 \mu\text{V}_{\text{RMS}}$		
Smoothing, off	$\leq 2 \text{ mV}_{\text{RMS}}$		
Part 5 Rise Time		17.5 ps	yes
Part 6 Acquisition Aberrations (with 067–1338–00 source)			no
0 to 300 ps	–7% to 12%		
300 ps to 5 ns	$\pm 4\%$		
5 ns to 100 ns	$\pm 1.2\%$		
100 ns and up	$\pm 0.6\%$		
–10 ns to –20 ps	$\pm 4\%$		
Part 7 Coincidence Between Channels		10 ps	no
Part 8 Maximum Signal Voltage	1% of step amplitude		no
Part 9 Isolation Between Channels		1%	no
Part 10 Output Amplitude		250 mV \pm 5 mV	yes
Part 11 TDR Aberrations			no
0 to 300 ps	–5% to 15%		
300 ps to 5 ns		$\pm 3\%$	
5 ns and up		$\pm 1\%$	
–10 ns to –20 ps		$\pm 3\%$	
Part 12 Reflected Rise Time		35 ps	no

Test Equipment

Table 2-2 lists test equipment suggested for use with this manual. Procedure steps are based on the test equipment examples given, but other equipment with similar specifications may be substituted. Test results, setup information, and related connectors and adapters may be altered by the use of different equipment.

Table 2-2: Test Equipment

Description	Minimum Specification	Examples of Applicable Test Equipment
11800 Series or CSA 803 Series instrument	Tektronix digital sampling oscilloscope or communications signal analyzer	Tektronix 11800 Series Digital Sampling Oscilloscope or Tektronix CSA 803 Series Communications Signal Analyzer
Pulse Generator	1 ns rise time, 5 V output, 10 Hz to 250 MHz frequency range	Tektronix PG 502 Pulse Generator with a TM 500 Series Power Module
Time Mark Generator	1 ns through 5 s markers in a 1–2–5 sequence, at least 5 parts in 10^7 accuracy	Tektronix TG 501A Time Mark Generator with a TM 500 Series Power Module
Calibration Generator	DC output, 0.5% accuracy 1 V output amplitude	Tektronix PG 506A Calibration Generator with a TM 500 Series Power Module
Calibration Step Generator		Tektronix 067–1338–0X Calibration Step Generator (where X represents either a 0, 1, 2, 3, 5, or 6; depending on the power supply appropriate for your country. Refer to Section 5, <i>Replaceable Parts</i>)
System Controller	Any compatible controller with MS DOS and a serial port configured for COM1	IBM compatible PC with terminal emulation software
50 Ω Termination, SMA connectors	Impedance 50 Ω , SMA male connector	Tektronix Part 015–1022–00
50 Ω Termination, BNC connectors	Impedance 50 Ω , BNC connectors	Tektronix Part 011–0049–01
Precision Short Circuit Termination	Female 3.5 mm compatible connectors	Tektronix Part 011–0150–00
Precision 6-inch Semi-Rigid Cable	Male to male 3.5 mm compatible connectors	Tektronix Part 015–0564–00

Table 2-2: Test Equipment (Cont.)

Description	Minimum Specification	Examples of Applicable Test Equipment
Short Circuit Terminators, SMA Connections (2 required)	Male SMA Connectors	Tektronix Part 015–1020–00
Coaxial Cable, 50 Ω (2 required)	50 Ω, 36-inch, male BNC connectors	Tektronix Part 012–0482–00
Serial Cable	10-ft RS-232-C Cable	Tektronix Part 012–0911–00
Adapter, SMA to BNC (2 required)	male SMA to female BNC	Tektronix Part 015–0554–00
Attenuator, 2X	6 dB attenuation, 50 Ω, one male and one female BNC	Tektronix Part 011–0069–02
Attenuator, 5X	14 dB attenuation, 50 Ω, one male and one female BNC	Tektronix Part 011–0060–02
Wrist Strap		Tektronix Part 006–3415–01
Static Control Mat		Tektronix Part 006–3414–00
Needle-Nose Pliers		
Pozidrive Screwdriver	P1 tip	

Using These Procedures

Each part begins with a setup illustration that shows what test equipment is needed and how to connect it. Refer to Table 2-2 for an example of the test equipment for each part.

Conventions in this Manual

In these procedures, the following conventions are used:

- CAPITAL letters within the body of text identify front panel controls, indicators, and connectors (for example, MEASURE) on the instrument and sampling head.
- **Bold** letters identify menu labels and display messages.
- Initial Capital letters identify connectors, controls, and indicators (for example, Position) on associated test equipment. Initial Capital letters also identify adjustments inside the sampling head.

In some steps, the first word is italicized to identify a step that contains a performance verification and/or an adjustment instruction. For example, if *Check* is the first word in the title of a step, an electrical specification is checked. If *Adjust* appears in the title, the step involves an electrical adjustment. If *Examine* is the first word in the title, the step concerns measurement limits that indicate whether the sampling head is operating properly; these limits are not to be interpreted as electrical specifications.

Initialized and Stored Settings

At the beginning of most steps, the user is instructed to **Initialize** the instrument as part of the setup. The **Initialize** feature, available through the UTILITY menu, presets all instrument controls and functions to known values. Initializing the instrument at the beginning of a step eliminates the possibility of settings from previous parts causing erroneous or confusing results.

Menu Selections and Measurement Techniques

Details on measurement techniques and instructions for making menu selections are generally not included in this manual. Comprehensive descriptions of menus and instrument features are located in the *User Manual* for your instrument and the *SD-24 TDR/Sampling Head User Manual*.

Setup Illustrations

You can use any 11800 Series Digital Sampling Oscilloscope or CSA 803 Series Communications Signal Analyzer as the mainframe instrument in these procedures. A “Mainframe Instrument” is shown in each procedure; the exact location of connectors on your mainframe instrument may differ from that shown in the illustration.

In particular, the 11802 Oscilloscope and CSA 803 Series Communications Signal Analyzers have only two sampling head acquisition compartments, as compared to four in the 11801 Series Oscilloscopes. Locations of controls and connectors on each instrument are shown in Figure 2-1.

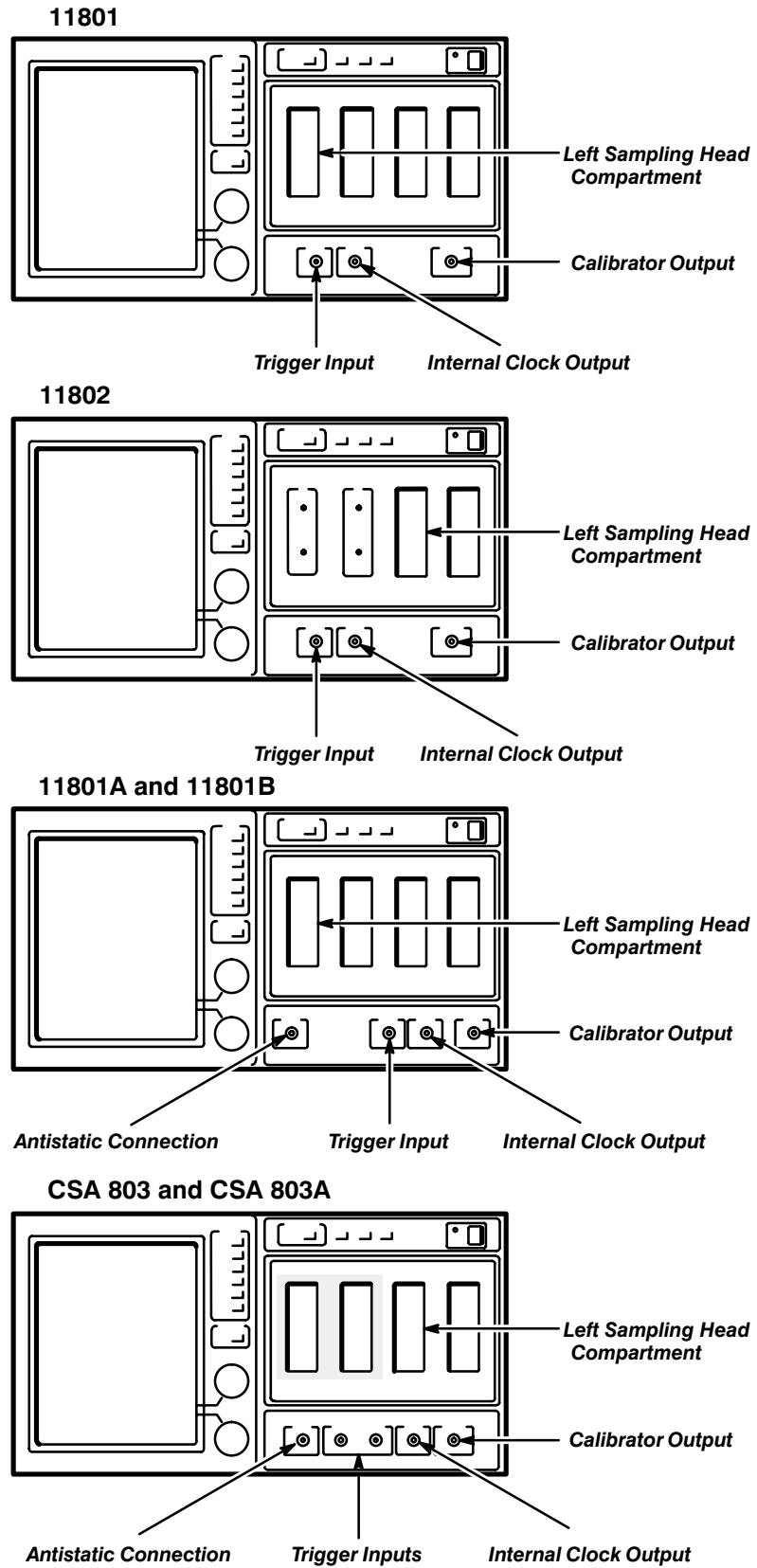
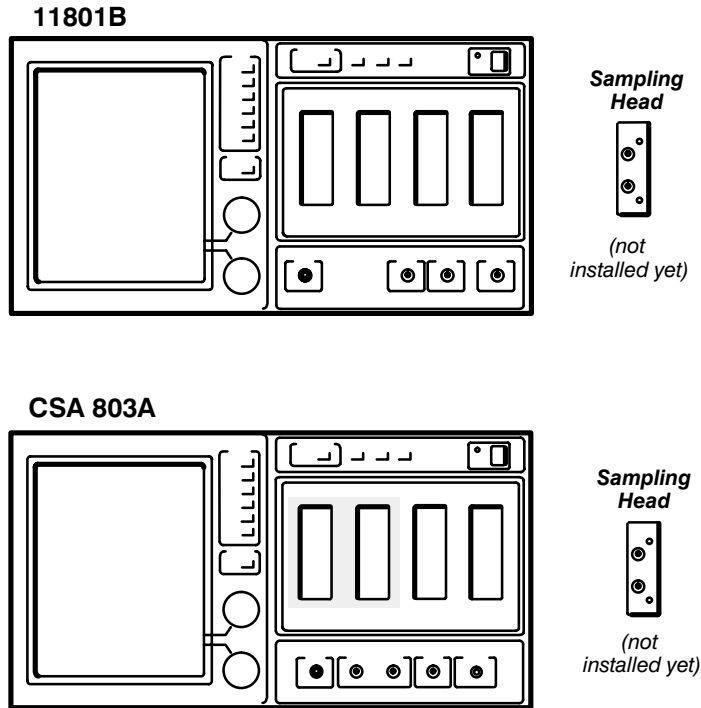

Figure 2-1: Locations of Controls and Connectors on Mainframe Instruments

**Part 1
Power-On**

Perform this part within the ambient temperature range of +18° C and +28° C, to assure proper instrument operation.

Setup to Power-On



Procedure to Power On

- Step 1:** Set the following in the order listed:
 Sampling Head Not installed yet
 Instrument Mainframe
 ON/STANDBY switch STANDBY
- Step 2:** Install the SD-24 sampling head in the instrument's left-most compartment.
- Step 3:** With the instrument's rear panel PRINCIPAL POWER SWITCH set to OFF, connect the instrument to a suitable power source.
- Step 4:** Set the rear panel PRINCIPAL POWER SWITCH to ON and then the instrument's front panel ON/STANDBY switch to ON.

When the instrument is first installed, the rear panel PRINCIPAL POWER SWITCH should be set to and remain in the ON position. Then, use the front panel ON/STANDBY switch to perform all subsequent power switching.

Step 5: Power-on the following test equipment, so that it is warmed up with the instrument to be tested:

- Calibration generator
- Calibration step generator
- Time mark generator
- Pulse generator

A complete list of test equipment is in Table 2-2.

- Before doing the performance checks, allow a 20 minute warm-up for the Sampling head and test equipment.

Part 2 Dot Transient Response

This part shows the setup and lists the procedures to check the dot transient response. The dot transient response is examined at 250 mV and 500 mV with automatic calibration settings, at 500 mV with default settings, and checked at 1 V with manual calibration settings.

Measurement Limits

The measurement limits for the dot transient response error are:

- $\leq 5\%$ error when measured at 250 mV and 500 mV with automatic calibration settings
- $\leq 20\%$ error when measured at 500 mV with default settings

Specifications

The specification for the dot transient response at 1 V is that the amplitude is adjustable to 100%.

Setup to Check Dot Transient Response

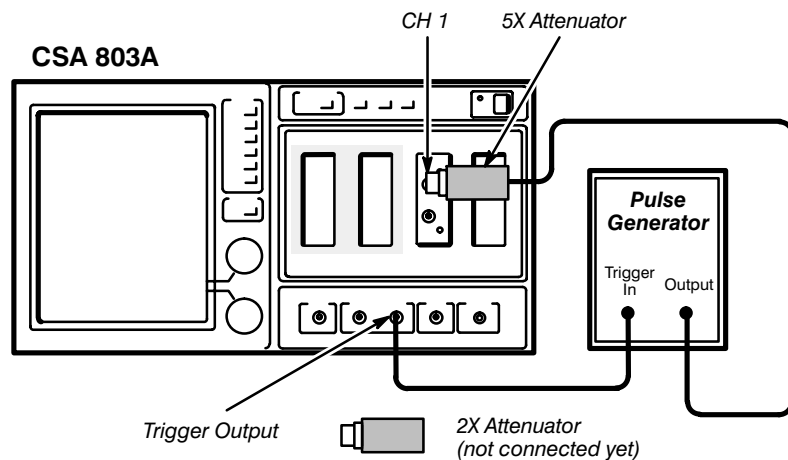
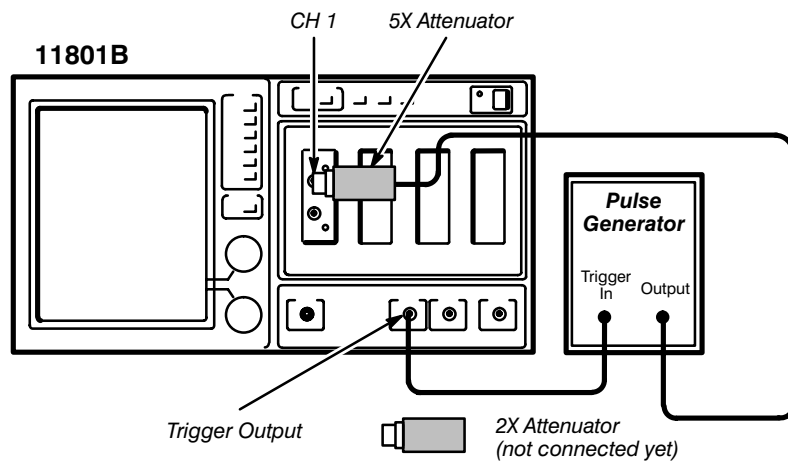

Procedure to Check Dot Transient Response

- Step 1:** Initialize the instrument settings, then make the following settings in the order listed:

Sampling Head

CH 1 SELECT CHANNEL On/Off On

Instrument Mainframe

Vert Size: M1 50 mV/division

TRIGGER button press

Source **Internal Clock**

Main Pos **Min**

Main Size 20 ns/division

Pulse Generator

Back Terminator button pull out

Trigger Source External Trigger

Output square wave

Examine Dot Response at 250 mV with Automatic Calibration Settings — by performing Steps 2 through 32.

- Step 2:** Set the pulse generator's amplitude for a 375 mV display.
- Step 3:** Set the **Vert Offset: M1** so that the step is approximately centered on the screen.
- Step 4:** Press the UTILITY button and touch **Enhanced Accuracy** (11801A/B and CSA 803 Series) or press the ENHANCED ACCURACY button (11801/2).
- Step 5:** Touch **Loop Gain**.
- Step 6:** Touch **Automatic Calibrate** and then **Proceed** in the **Loop Gain Calibration** pop-up menu.
- Step 7:** Touch **Exit** in the **Loop Gain Calibration** pop-up menu.
- Step 8:** Set the pulse generator's amplitude for a 250 mV step display.
- Step 9:** Press the WAVEFORM button and then touch **Horizontal Desc**.
- Step 10:** Touch **Main Record Length** in the **Horizontal Description** pop-up menu and then set the top knob for a **Main Record Length** of 512.
- Step 11:** Press the UTILITY button and then **Instr Options**.
- Step 12:** Set **Vectored Trace** to **Off** in the **Instrument Options** pop-up menu.
- Step 13:** Touch **Display Intensity** in the **Instrument Options** pop-up menu and then set the top knob for **90%** intensity.
- Step 14:** Touch **Exit**.

- Step 15:** Touch **Cursors** on the top of the screen.
- Step 16:** Touch **Cursor Type** and then **Horizontal Bars** in the **Cursor Type** pop-up menu.
- Step 17:** Touch **Exit**.
- Step 18:** Set **Cursor 1** (top knob) to the average of the bottom of the pulse before the step.
- Step 19:** Set **Cursor 2** (bottom knob) to the top of the step.
- Step 20:** Read ΔV as the peak-to-peak step amplitude and then record this value as **V** for later use.
- Step 21:** Press the UTILITY button and touch **Enhanced Accuracy** (11801A/B and CSA 803 Series) or press the ENHANCED ACCURACY button (11801/2).
- Step 22:** Touch **Loop Gain** and then the channel you are using in the **Loop Gain Calibration** pop-up menu.
- Step 23:** Set the **Divide by Two Mode** to **On** in the **Loop Gain Calibration** pop-up menu.
- Step 24:** Touch **Exit** in the **Loop Gain Calibration** pop-up menu.
- Step 25:** Touch **Cursors** at the top of the screen.
- Step 26:** Set **Cursor 1** to the average of the bottom of the pulse before the step.
- Step 27:** Set **Cursor 2** to the average of the bottom of the pulse under the step.
- Step 28:** Read ΔV and then record this value as **V_L** for later use.
- Step 29:** Set **Cursor 2** to the average of the top of the pulse.
- Step 30:** Read Δ , and then record this value as **V_H** for later use.
- Step 31:** *Examine* that the negative dot response error $[(-V_L/V_H) \times 100\%]$ is $\leq 5\%$.
- Step 32:** *Examine* that the positive dot response error $[100\% \times (V_H - V)/(V - V_L)]$ is $\leq 5\%$.

Examine Dot Response at 500 mV with Automatic Calibration Settings — by performing Steps 33 through 52.

- Step 33:** Press the UTILITY button and touch **Enhanced Accuracy** (11801A/B and CSA 803 Series) or press the ENHANCED ACCURACY button (11801/2).
- Step 34:** Touch **Loop Gain** and then set **Divide by Two Mode** to **Off** in the **Loop Gain Calibration** pop-up menu.

- Step 35:** Touch **Exit**.
- Step 36:** Set the **Vert Size:M1** to 100 mV/div.
- Step 37:** Set the pulse generator's amplitude for a 500 mV step display.
- Step 38:** Touch **Cursors** on the top of the screen.
- Step 39:** Set **Cursor 1** to the average of the bottom of the pulse before the step.
- Step 40:** Set **Cursor 2** to the average of the top of the pulse.
- Step 41:** Read ΔV as the peak-to-peak step amplitude and then record this value as **V** for later use.
- Step 42:** Press the UTILITY button and touch **Enhanced Accuracy** (11801A/B and CSA 803 Series) or press the ENHANCED ACCURACY button (11801/2).
- Step 43:** Touch **Loop Gain** and then the channel number you are using in the **Loop Gain Calibration** pop-up menu.
- Step 44:** Set **Divide by Two Mode** to **On** in the **Loop Gain Calibration** pop-up menu.
- Step 45:** Touch **Cursors** at the top of the screen.
- Step 46:** Set **Cursor 1** to the average of the bottom of the pulse before the step.
- Step 47:** Set **Cursor 2** to the average of the bottom of the pulse after the step.
- Step 48:** Read the ΔV value and then record this value as **VL** for later use.
- Step 49:** Set **Cursor 2** to the average of the top of the pulse.
- Step 50:** Read ΔV , and then record this value as **VH** for later use.
- Step 51:** *Examine* that the negative dot response error $[(-V_L/V_H) \times 100\%]$ is $\leq 5\%$.
- Step 52:** *Examine* that the positive dot response error $[100\% \times (V_H - V)/(V - V_L)]$ is $\leq 5\%$.

Examine Dot Response at 500 mV with default settings — by performing Steps 53 through 61.

- Step 53:** Press the UTILITY button and touch **Enhanced Accuracy** (11801A/B and CSA 803 Series) or press the ENHANCED ACCURACY button (11801/2).
- Step 54:** Touch **Loop Gain** and then **Recall Defaults** in the **Loop Gain Calibration** pop-up menu.

- Step 55:** Touch **Exit**.
- Step 56:** Touch **Cursors** at the top of the screen.
- Step 57:** Set **Cursor 1** to the average of the bottom of the pulse before the step.
- Step 58:** Set **Cursor 2** to the average of the bottom of the pulse after the step.
- Step 59:** Read the ΔV value and then record this value as **VL** for later use.
- Step 60:** Set **Cursor 2** to the average of the top of the pulse and read ΔV . Record this value as **VH**.
- Step 61:** *Examine* that the magnitude of the negative dot response error $[(-VL/VH) \times 100\%]$ is $\leq 20\%$.

Check Dot Response at 1V with Manual Calibration Settings — by performing Steps 62 through 73.

- Step 62:** Press the UTILITY button and touch **Enhanced Accuracy** (11801A/B and CSA 803 Series) or press the ENHANCED ACCURACY button (11801/2).
- Step 63:** Touch **Loop Gain** and then set the **Divide by Two Mode** to **Off** in the **Loop Gain Calibration** pop-up menu.
- Step 64:** Touch **Exit**.
- Step 65:** Remove the $5\times$ attenuator and then connect the $2\times$ attenuator to the channel you are using and the coaxial cable.
- Step 66:** Set the **Vert Size:M1** to 200 mV/div.
- Step 67:** Set the pulse generator's amplitude for a $1\text{ V} \pm 2\%$ step display.
- Step 68:** Press the UTILITY button and touch **Enhanced Accuracy** (11801A/B and CSA 803 Series) or press the ENHANCED ACCURACY button (11801/2).
- Step 69:** Touch **Loop Gain** and then the channel number you are using in the **Loop Gain Calibration** pop-up menu.
- Step 70:** Set the **Divide by Two Mode** to **On** and then touch **Manual Calibrate** in the **Loop Gain Calibration** pop-up menu.
- Step 71:** Touch **Exit**.
- Step 72:** *Check* that the amplitude of the pulse, measured from the average of the level under the pulse to the average of the top of the pulse, can be set with the manual calibration settings to be $\geq 1\text{V}$.
- Step 73:** Repeat Steps 2 through 72 for channel 2.

Part 3 Offset

This part shows the setup and lists the procedure to examine offset and check offset change with repetition rate.

Measurement Limits

The measurement limit for the offset is $0\text{ V} \pm 2\text{ mV}$.

Specifications

The specification for the offset change with repetition rate is $0\text{ V} \pm 5\text{ mV}$.

Setup to Examine Offset

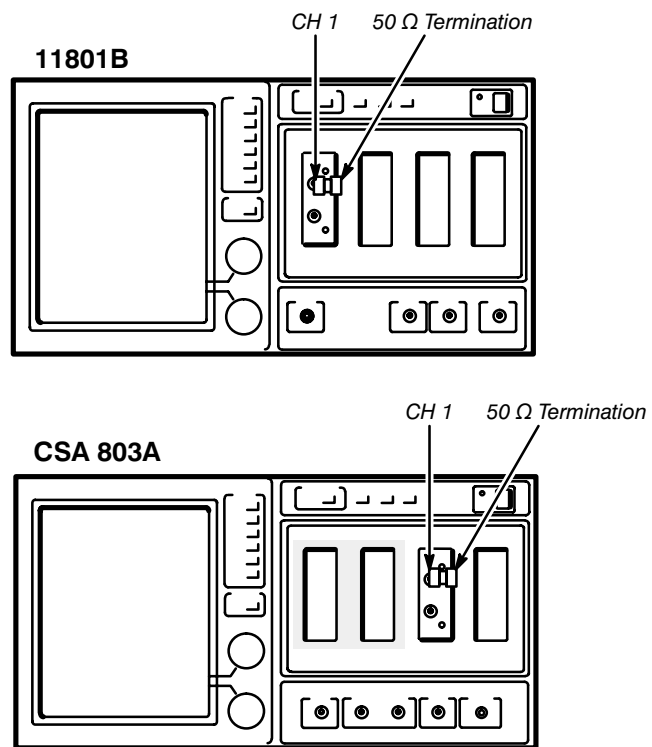

Procedure to Examine Offset

- Step 1:** Initialize the instrument settings, then make the following settings in the order listed:

Sampling Head

CH 1 SELECT CHANNEL On/Off On

Instrument Mainframe

TRIGGER button press

Source **Internal Clock**

ENHANCED ACCURACY button (11801/2) press

UTILITY button (11801A/B, CSA 803 Series) press

Enhanced Accuracy (11801A/B, CSA 803 Series) touch

Calibrate All pop-up menu **Recall Defaults**

- Step 2:** Touch **Offset Null** in the **Enhanced Accuracy** menu.
- Step 3:** Touch **Manual Calibrate** in the **Offset Nulling** pop-up menu.
- Step 4:** Touch the **Offset Null: M1**, select **0**, and then touch **Enter** in the **Numeric Entry & Knob Res** pop-up menu.
- Step 5:** Touch the vertical (\updownarrow) icon and then set **Vert Size: M1** to 50mV/div.
- Step 6:** Press the MEASURE button.
- Step 7:** Touch **Measurements** and then **Mean** in the **Measurements** pop-up menu.
- Step 8:** Touch **Mean** in the MEASURE major menu, and then set **Data Interval** to **whole zone** in the **Mean** pop-up menu.
- Step 9:** *Examine* that **Mean** is 0 V \pm 200 mV.
- Step 10:** Press the UTILITY button and touch **Enhanced Accuracy** (11801A/B and CSA 803 Series) or press the ENHANCED ACCURACY button (11801/2).
- Step 11:** Touch **Offset Null**.
- Step 12:** Touch **Automatic Calibrate** and then **Proceed** in the **Offset Nulling** pop-up menu.
- Step 13:** Press the MEASURE button.
- Step 14:** *Examine* that the **Mean** (offset) is 0 V \pm 2 mV.
- Step 15:** Repeat Steps 2 through 14 for Channel 2.

Setup to Check Offset Change with Repetition Rate

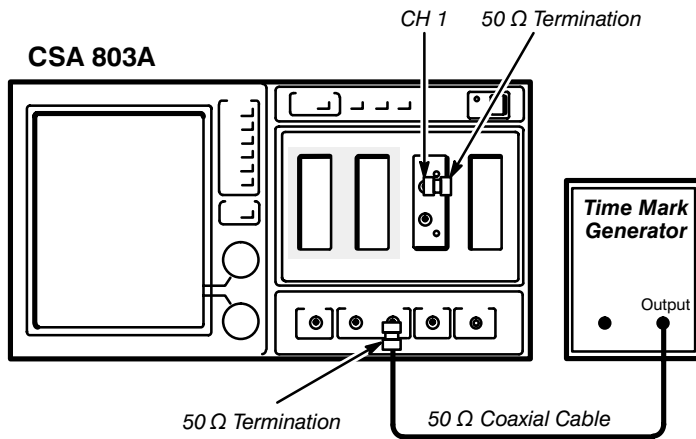
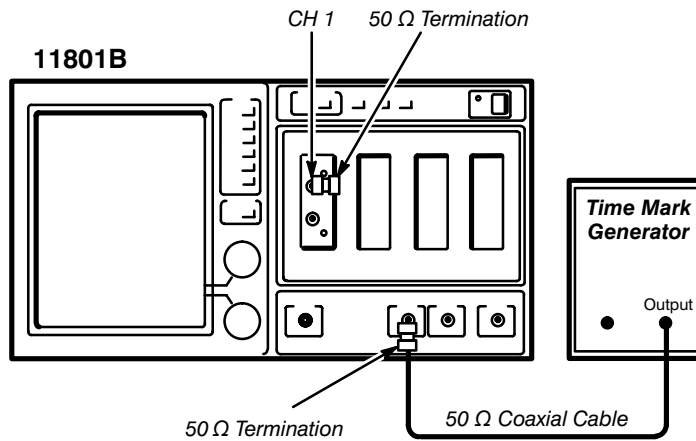

Procedure to Check Offset Change with Repetition Rate

- Step 1:** Initialize the instrument settings, then make the following settings in the order listed:

Sampling Head

CH 1 SELECT CHANNEL On/Off On

Instrument Mainframe

ENHANCED ACCURACY button (11801/2) press

UTILITY button (11801A/B, CSA 803 Series) press

Enhanced Accuracy (11801A/B, CSA Series) touch

Calibrate All pop-up menu **Recall Defaults**

Time Mark Generator

Marker (sec) 0.2 μ s

- Step 2:** Press the TRIGGER button and then touch **Level**.

- Step 3:** Adjust the **Trig Level** until a trace appears.

- Step 4:** Touch the vertical (\updownarrow) icon and then set the **Vert Size: M1** to 2 mV/div.
- Step 5:** Set **Vert Offset: M1** so that the trace is vertically centered on the screen.
- Step 6:** Set the time mark generator's Marker setting to 10 ms.
- Step 7:** Press the WAVEFORM button and then touch **Acquire Desc.**
- Step 8:** Set **Average N** to **On** and then touch **Set Avg N.**
- Step 9:** Set **Average N** to **8** with the top knob.
- Step 10:** Wait until the **Acquire Desc** selector in the WAVEFORM major menu shows that eight averages have been completed.
- Step 11:** Press the MEASURE button.
- Step 12:** Touch **Measurements** and then **Mean** in the **Measurements** pop-up menu.
- Step 13:** Touch **Compare & References** in the MEASURE major menu.
- Step 14:** Touch **Save Current Meas Values as References** and then set **Compare** to **On.**
- Step 15:** Set the time mark generator's Marker setting to 5 ms.
- Step 16:** Wait until the **Acquire Desc** selector in the WAVEFORM major menu shows that eight averages have been completed.
- Step 17:** *Check* that **Δ Mean** (offset with a repetition rate) is $0\text{ V} \pm 5\text{ mV}$.
- Step 18:** Continue to decrease the time mark generator's Marker setting and repeat Step 17 for each setting down to $0.1\ \mu\text{s}$.
- Step 19:** Press the CH 2 SELECT CHANNEL button.
- Step 20:** Disconnect the $50\ \Omega$ termination from the CH 1 input and connect it to the CH 2 input.
- Step 21:** Repeat Steps 4 through 18 for CH 2.

Part 4 Noise

This part shows the setup and lists the procedures to check noise.

Measurement Limits (SN B020652 and above)

The measurement limit for noise is 1.2 mV without smoothing and 550 μ V with smoothing.

Measurement Limits (SN B010651 and below)

The measurement limit for noise is 2 mV without smoothing and 900 μ V with smoothing.

Setup to Examine Noise

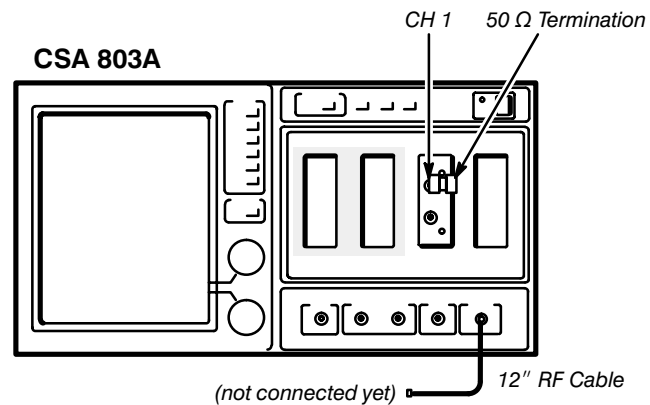
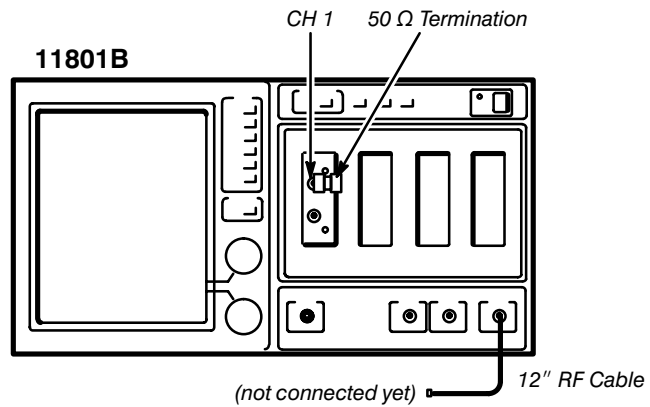

Procedure to Examine Noise

- Step 1:** Initialize the instrument settings, then make the following settings in the order listed:

Sampling Head

CH 1 SELECT CHANNEL On/Off On

Instrument Mainframe

TRIGGER button press

Source **Internal Clock**

ENHANCED ACCURACY button (11801/2) press

UTILITY button (11801A/B, CSA 803 Series) press

Enhanced Accuracy (11801A/B, CSA 803 Series) touch

Calibrate All pop-up menu **Recall Defaults**

- Step 2:** Touch **Loop Gain** in the **Enhanced Accuracy** menu.
- Step 3:** Disconnect the 50 Ω termination from the CH 1 input and connect the CALIBRATOR to the CH 1 input through the 12 inch RF cable.
- Step 4:** Touch the channel number you are using, **Automatic Calibrate**, and then **Proceed** in the **Loop Gain Calibration** pop-up menu.
- Step 5:** Disconnect the CALIBRATOR from the CH 1 input and reconnect the 50 Ω termination.
- Step 6:** Press the WAVEFORM button and then touch **Acquire Desc.**
- Step 7:** Set **Average N** to **On**.
- Step 8:** Press the AUTOSET button.
- Step 9:** Touch the vertical (\downarrow) icon then set the **Vert Size: M1** to 2 mV/div.
- Step 10:** Touch **Def Tra** at the top of the screen.
- Step 11:** In the **Vertical Description** pop-up menu, touch the following selectors in the order given:
Mainframe (11801 Series only), **1. -**, **Avg (**, **Mainframe** (11801 Series only), **1,)**, **Enter Desc**
- Step 12:** Press the MEASURE button and then touch **Measurements**.
- Step 13:** Touch **RMS** in the **Measurements** pop-up menu and then **RMS** in the MEASURE major menu.
- Step 14:** Set **Data Interval** to **whole zone** in the **RMS** pop-up menu.
- Step 15:** *Examine* that **RMS** is ≤ 1.2 mV. (SN B020652 and above)
Examine that **RMS** is ≤ 2 mV. (SN B010651 and below)
- Step 16:** Press the WAVEFORM button.

- Step 17:** Touch **Sampling Head Fnc's** and then set **Smoothing** to **On** in the **Sampling Head Functions** pop-up menu.
- Step 18:** Press the MEASURE button.
- Step 19:** *Examine* that the **RMS** is $\leq 550 \mu\text{V}$. (SN B020652 and above)
Examine that the **RMS** is $\leq 900 \mu\text{V}$. (SN B010651 and below).
- Step 20:** Repeat Steps 2 through 19 for channel 2.

Part 5 Rise Time

This part shows the setup and lists the procedure to check the rise time.

Specifications

The specification for the sampling head rise time is 17.5 ps.

Setup to Check Rise Time

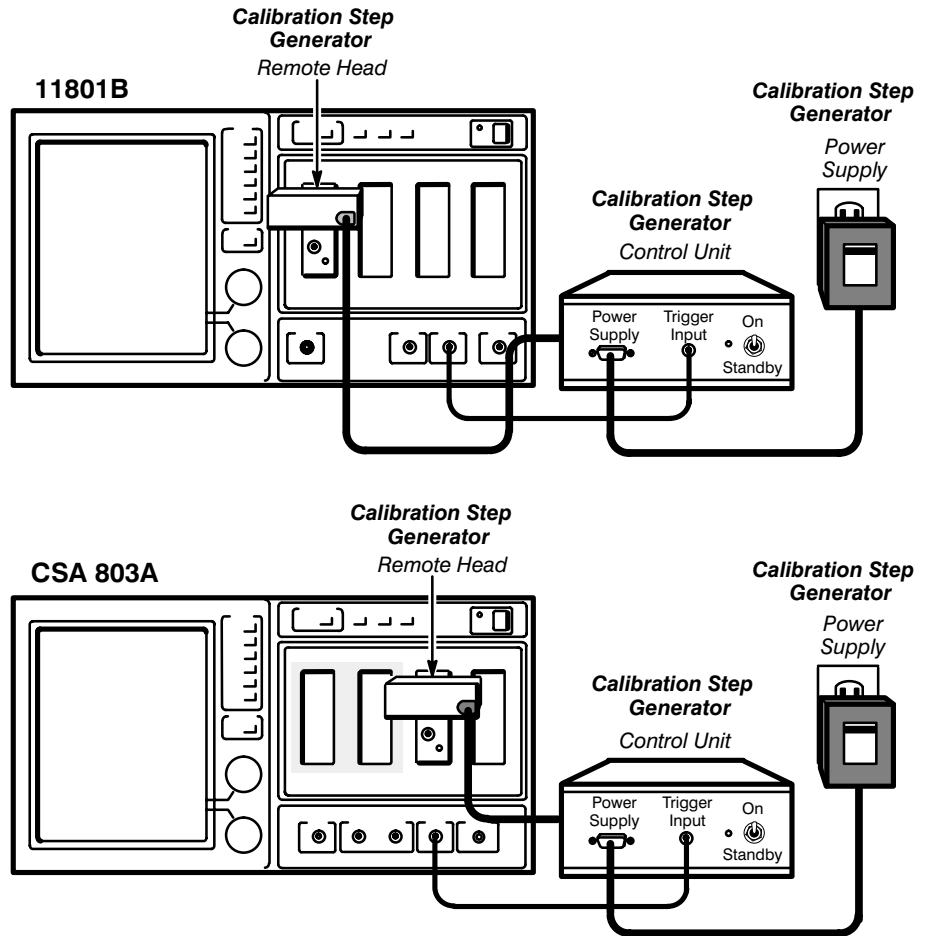

Procedure to Check Rise Time

- Step 1:** Initialize the instrument settings, then make the following settings in the order listed:

Sampling Head

CH 1 SELECT CHANNEL On/Off On

Instrument Mainframe

ENHANCED ACCURACY button (11801/2) press

UTILITY button (11801A/B, CSA 803 Series) press

Enhanced Accuracy (11801A/B, CSA 803 Series) touch

Calibrate All pop-up menu **Recall Defaults**

TRIGGER button press

Source **Internal Clock**

Calibration Step Generator

ON/STANDBY switch ON

- Step 2:** Press the AUTASET button.
- Step 3:** Press the WAVEFORM button and then touch **Horizontal Desc.**
- Step 4:** Touch **Main Record Length** and then set **Main Record Len** to 5120 with the top knob.
- Step 5:** Touch **Acquire Desc** in the WAVEFORM major menu.
- Step 6:** Set **Average N** to **On** and then touch **Set Avg N**.
- Step 7:** Set **Average N** to 128 with the top knob.
- Step 8:** Touch the horizontal (↔) icon and then set the **Main Size** to 100 ns/div.
- Step 9:** Touch **Main Pos** and then **Set to Min** in the **Numeric Entry & Knob Res** pop-up menu.
- Step 10:** Press the MEASURE button.
- Step 11:** Touch **Measurements** and then **Rise** in the **Measurements** pop-up menu.
- Step 12:** Touch **Rise** in the MEASURE major menu and then set **Tracking** to **Off** in the **Rise** pop-up menu.
- Step 13:** Set the **Main Size** to 5 ns/div.
- Step 14:** Touch **Baseline** in the **Rise** pop-up menu.
- Step 15:** Touch a blank portion of the screen to exit this menu.
- Step 16:** Set the **Baseline** (bottom knob) to the average of the bottom of the pulse 10 ns before the step.
- Step 17:** Touch the horizontal (↔) icon and then set the **Main Pos** so that the step is at the left-most edge of the screen.

Checks and Adjustments

- Step 18:** Set the **Main Size** to 20 ps/div.
- Step 19:** Set the **Main Pos** so that the step is approximately centered on the screen.
- Step 20:** Touch **Rise** in the MEASURE major menu.
- Step 21:** Record the **Mean:** value in the **Rise** pop-up menu for later use.
- Step 22:** Calculate the sampling head rise time with the following formula:

$$\text{sampling head rise time} = \sqrt{(\text{Mean : value})^2 - (\text{Calibration Step Generator rise})^2}$$

NOTE

Calibration Step Generation rise is read from the calibration step generator.

- Step 23:** Check that the sampling head rise time is ≤ 17.5 ps.
- Step 24:** Repeat Steps 2 through 23 for channel 2.

Part 6 Acquisition Aberrations

This part shows the setup and lists the procedures to check acquisition aberrations.

Measurement Limits

The measurement limits for acquisition aberrations are listed in Table 2-3, Acquisition Aberration Specifications.

Table 2-3: Acquisition Aberration Specifications

Time Difference from the Rising Edge of Waveform	Minimum Specification
0 to 300 ps	$-7\% \leq \text{aberration \%} \leq 12\%$
300 ps to 5 ns	$-4\% \leq \text{aberration \%} \leq 4\%$
5 ns to 100 ns	$-1.2\% \leq \text{aberration \%} \leq 1.2\%$
100 ns and up	$-0.6\% \leq \text{aberration \%} \leq 0.6\%$
-10 ns to -20 ps	$-4\% \leq \text{aberration \%} \leq 4\%$

Setup to Examine Acquisition Aberrations

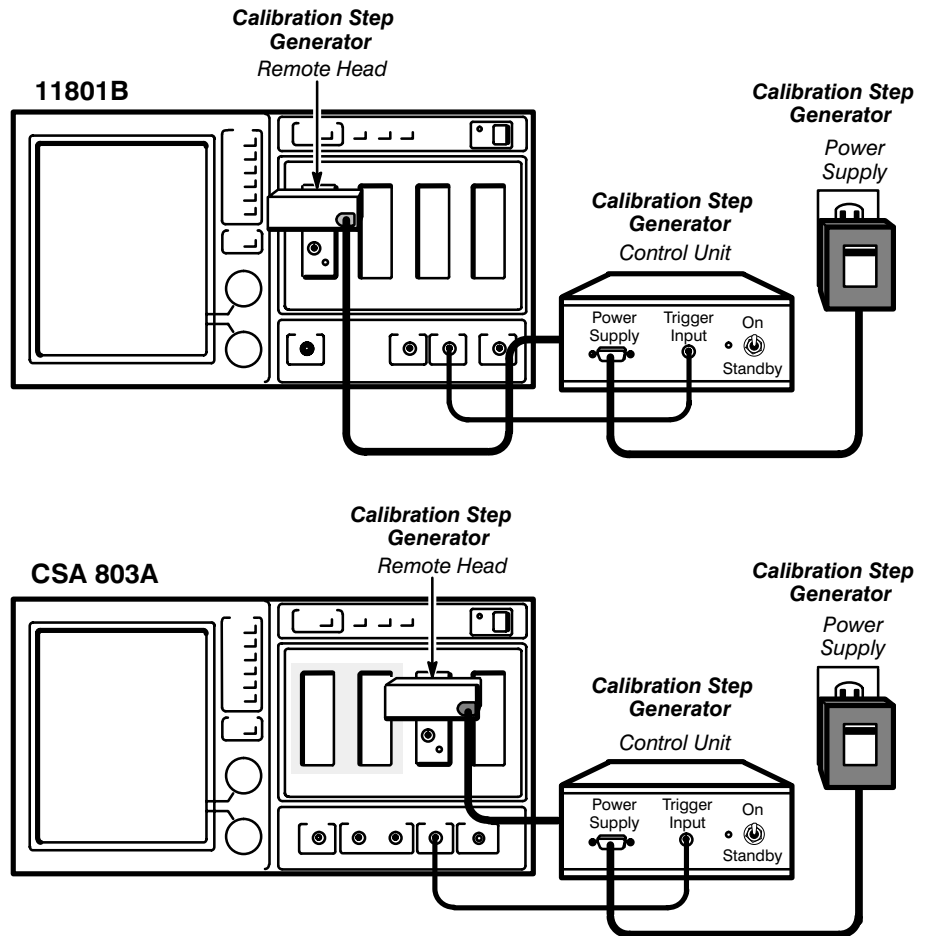

Procedure to Examine Acquisition Aberrations

- Step 1:** Initialize the instrument settings, then make the following settings in the order listed:

Sampling Head

CH1 SELECT CHANNEL On/Off On

Instrument Mainframe

ENHANCED ACCURACY button (11801/2) press

UTILITY button (11801A/B, CSA 803 Series) press

Enhanced Accuracy (11801A/B, CSA 803 Series) touch

Calibrate All pop-up menu **Recall Defaults**

TRIGGER button press

Source **Internal Clock**

Calibration Step Generator

ON/STANDBY switch ON

- Step 2:** Press the WAVEFORM button and then touch **Acquire Desc.**
- Step 3:** Set **Average N** to **On** and then touch **Set Avg N.**
- Step 4:** Set **Average N** to 128 with the top knob.
- Step 5:** Press the AUTOSET button.
- Step 6:** Touch the horizontal (↔) icon and then set the **Main Size** to 100 ns/div.
- Step 7:** Set the **Main Pos** so that the rising edge of the step is at the left-most edge of the screen.
- Step 8:** Touch the vertical (↕) icon and then set the **Vert Offset:M1** so that the average of the top of the pulse between 100 ns after the step and the right edge of the screen is at the horizontal centerline.
- Step 9:** Set the **Vert Size: M1** to 2 mV/div.
- Step 10:** Touch **Vert Offset: M1** and then **Fine** in the **Numeric Entry & Knob Res** pop-up menu.
- Step 11:** Set **Vert Offset: M1** so that the average of the top of the pulse between 100 ns after the step and the right edge of the screen is at the horizontal centerline.
- Step 12:** *Examine* that the magnitude of the maximum positive and negative aberrations that occur 100 ns after the step is ≤ 0.75 vertical divisions from the horizontal centerline (0.6% of the step amplitude).
- Step 13:** Touch the horizontal (↔) icon and then set the **Main Size** to 10 ns/div.
- Step 14:** Set the **Main Pos** so that the rising edge of the step is at the left-most edge of the screen.
- Step 15:** *Examine* that the magnitude of the maximum positive and negative aberrations that occur between 5 ns and 100 ns after the step is ≤ 1.5 vertical divisions from the horizontal centerline (1.2% of the step amplitude).
- Step 16:** Set the **Main Size** to 500 ps/div and then the **Main Pos** so that the rising edge of the step is at the left-most edge of the screen.
- Step 17:** *Examine* that the magnitude of the maximum positive and negative aberrations that occur between 300 ps and 5 ns after the step is ≤ 5.0 vertical divisions from the horizontal centerline (4.0% of the step amplitude).
- Step 18:** Touch the horizontal (↔) icon and then set the **Main Size** to 500 ns/div.
- Step 19:** Touch the vertical (↕) icon and then set the **Vert Size:M1** to 10 mV/div.

- Step 20:** Set the **Vert Offset:M1** so that the average of the top of the pulse between 100 ns after the step and the right edge of the screen is at the horizontal centerline.
- Step 21:** Touch the horizontal (↔) icon and then set the **Main Size** to 50 ps.
- Step 22:** Set the **Main Pos** so that the rising edge of the step is at the left-most edge of the screen.
- Step 23:** *Examine* that the magnitude of the maximum positive aberration that occurs in the first 300 ps after the step is ≤ 3.0 vertical divisions from the horizontal centerline (12% of the step amplitude).
- Step 24:** *Examine* that the magnitude of the maximum negative aberration that occurs in the first 300 ps after the step is ≤ 1.75 vertical divisions from the horizontal centerline (7% of the step amplitude).
- Step 25:** Touch the **Main Pos** selector and then **Set to Min** in the **Numeric Entry and Knob Res** pop-up menu.
- Step 26:** Set the **Main Size** to 10 ns/div.
- Step 27:** Touch the vertical (↑↓) icon and then set **Vert Offset:M1** so that the average of the bottom of the pulse 10 ns before the step is at the horizontal centerline.
- Step 28:** Touch the horizontal (↔) icon and then set the **Main Size** to 1 ns/div.
- Step 29:** Set the **Main Pos** so that the rising edge of the step is at the right-most edge of the screen.
- Step 30:** *Examine* that the magnitude of the maximum positive and negative aberrations that occur between 10 ns and 500 ps before the 10% point of the step is ≤ 1.0 vertical divisions from the horizontal centerline (4% of the step amplitude).
- Step 31:** Set the **Main Size** to 50 ps/div and then the **Main Pos** so that the rising edge of the step is at the right-most edge of the screen.
- Step 32:** *Examine* that the magnitude of the maximum positive and negative aberrations that occur between 500 ps and 20 ps before the 10% point of the step is ≤ 1.0 vertical divisions from the horizontal centerline (4% of the step amplitude).
- Step 33:** Repeat Steps 2 through 32 for channel 2.

Part 7 Coincidence Between Channels

This part shows the setup and lists the procedures to check the coincidence between channels.

Specifications

The specification for the coincidence between channels is 10 ps.

Setup to Check Coincidence Between Channels

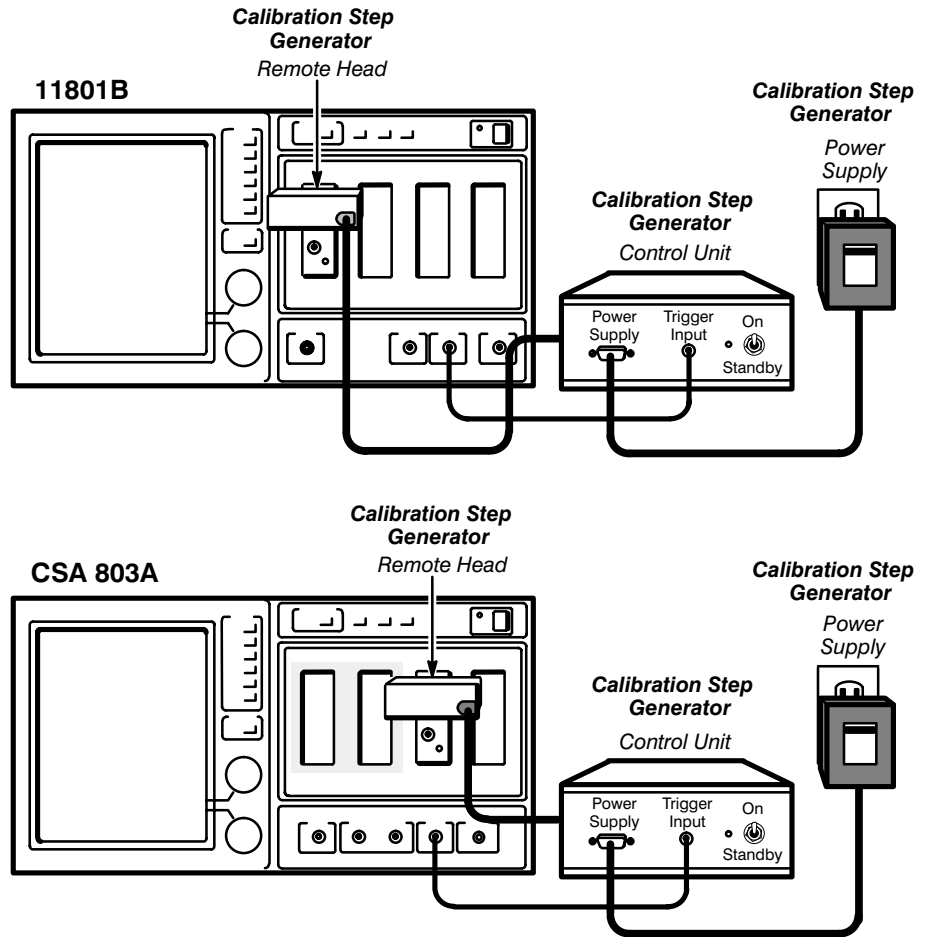

Procedure to Check Coincidence Between Channels

- Step 1:** Initialize the instrument settings, then make the following settings in the order listed:

Sampling Head

CH 1 SELECT CHANNEL On/Off On

Instrument Mainframe

ENHANCED ACCURACY button (11801/2) press

UTILITY button (11801A/B, CSA 803 Series) press

Enhanced Accuracy (11801A/B, CSA 803 Series) touch

Calibrate All pop-up menu **Recall Defaults**

TRIGGER button press

Source **Internal Clock**

Calibration Step Generator

ON/STANDBY switch ON

- Step 2:** Press the AUTOSET button.
- Step 3:** Press the WAVEFORM button and then touch **Horizontal Desc.**
- Step 4:** Touch **Main Record Length** and then set **Main Record Len** to 1024 with the top knob.
- Step 5:** Touch **Acquire Desc** in the WAVEFORM major menu.
- Step 6:** Set **Average N** to **On** and then touch **Set Avg N**.
- Step 7:** Set **Average N** to 64 with the top knob.
- Step 8:** Disconnect the calibration step generator remote head from CH 1, connect it to CH 2, and then press the CH 2 SELECT CHANNEL On/Off button.
- Step 9:** Press AUTOSET.
- Step 10:** Select the horizontal (↔) icon and then set the **Main Size** to 10 ps/div.
- Step 11:** Touch **Acquire Desc** and then set **Average N** to **On** in the **Acquire Description** pop-up menu.
- Step 12:** Touch **Exit**.
- Step 13:** Set the **Main Pos** so that the step is approximately centered on the screen.
- Step 14:** Press the STORE/RECALL button.
- Step 15:** Touch **Trace 2** in the **Store Trace** pop-up menu.
- Step 16:** Touch **Recall Trace** in the STORE/RECALL major menu.
- Step 17:** Touch **STO 1** in the **Recall Stored Trace** pop-up menu.

- Step 18:** Disconnect the calibration step generator remote head from CH 2, connect it to CH 1, and then press the CH 1 SELECT CHANNEL On/Off button.
- Step 19:** Press the MEASURE button.
- Step 20:** Touch **Measurements** and then **Prop Delay** in the **Measurements** pop-up menu.
- Step 21:** Touch **Prop Delay** in the MEASURE major menu and then **Trace 3** in the **Prop Delay** pop-up menu.
- Step 22:** *Check* that the magnitude of the **Prop Delay** is ≤ 10 ps.

Part 8 Maximum Signal Voltage

This part shows the setup and lists the procedure to examine the maximum signal voltage.

Measurement Limit

The measurement limit for the maximum signal voltage is 1% of the step amplitude.

Setup to Examine Maximum Signal Voltage

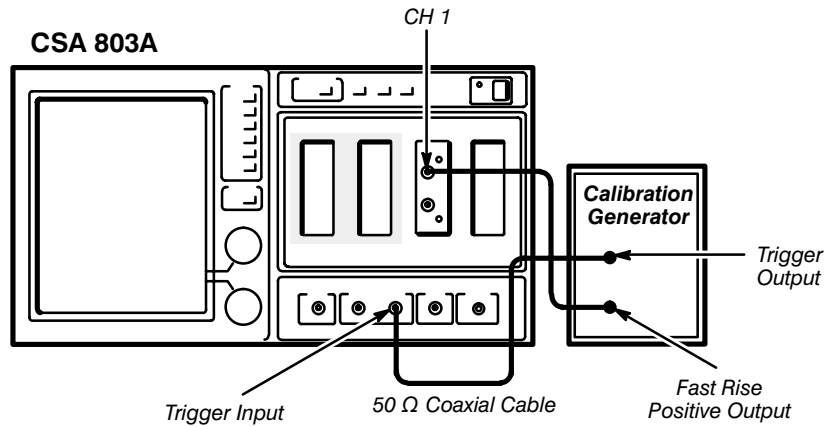
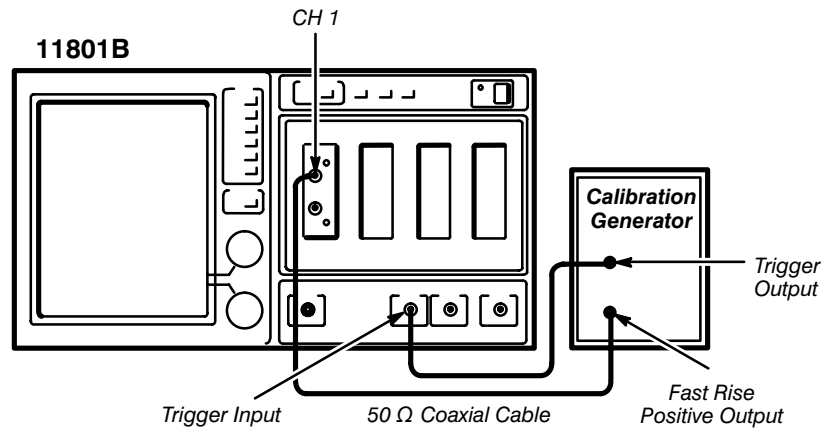

Procedure to Examine Maximum Signal Voltage

- Step 1:** Initialize the instrument settings, then make the following settings in the order listed:

Sampling Head

CH 1 SELECT CHANNEL On/Off On

Instrument Mainframe

ENHANCED ACCURACY button (11801/2) press

UTILITY button (11801A/B, CSA 803 Series) press

Enhanced Accuracy (11801A/B, CSA 803 Series) touch

Calibrate All pop-up menu **Recall Defaults**

TRIGGER button press

Slope -

Main Size 5 μ s/div

Calibration Generator

Amplitude maximum amplitude

Period 10 μ s

Var adjustment mid range

- Step 2:** Touch the vertical (\updownarrow) icon and then set the **Vert Offset: M1** so that the waveform is vertically centered on the screen.
- Step 3:** Set the calibration generator's amplitude so that it displays a 1 V peak-to-peak square wave.
- Step 4:** Touch the horizontal (\leftrightarrow) icon and then set the **Main Size** to 500 ns/div.
- Step 5:** Set the **Main Pos** so that the positive-going step is within $\frac{1}{2}$ division of the left-most edge of the screen.
- Step 6:** Press the WAVEFORM button.
- Step 7:** Touch **Acquire Desc** and then set **Average N** to **On** in the **Acquire Description** pop-up menu.
- Step 8:** Touch **Set Avg N** and then set **Average N** to 128 with the top knob.
- Step 9:** Touch the vertical (\updownarrow) icon and then set the **Vert Offset: M1** so that the average of the top of the pulse at 500 ns after the step is on the horizontal centerline.
- Step 10:** Set **Vert Size:M1** to 5 mV/div.
- Step 11:** Touch **Vert Offset: M1** and then **Fine** in the **Numeric Entry & Knob Res** pop-up menu.
- Step 12:** Set **Vert Offset: M1** so that the average of the top of the pulse at 500 ns after the step is on the horizontal centerline.
- Step 13:** Set the **Main Size** to 200 ns/div.

Checks and Adjustments

- Step 14:** *Examine* that the magnitude of the maximum positive and negative aberrations that occur between 200 ns and 800 ns after the rising edge of the step is ≤ 2 vertical divisions from the horizontal center-line (1% of the step amplitude).
- Step 15:** Touch the horizontal (\leftrightarrow) icon and then set the **Main Size** to 20 ns/div.
- Step 16:** Set the **Main Pos** so that the step is within 1/2 division of the left-most edge of the screen.
- Step 17:** *Examine* that the magnitude of the maximum positive and negative aberrations that occur between 10 ns and 200 ns after the rising edge of the step is ≤ 2 vertical divisions from the horizontal center-line (1% of the step amplitude).
- Step 18:** Repeat all of Part 8 for CH 2.

Part 9 Isolation Between Channels

This part shows the setup and lists the procedures to check the isolation between channels.

Specifications

The measurement limit for the isolation between channels is 1%.

Setup to Check Isolation Between Channels

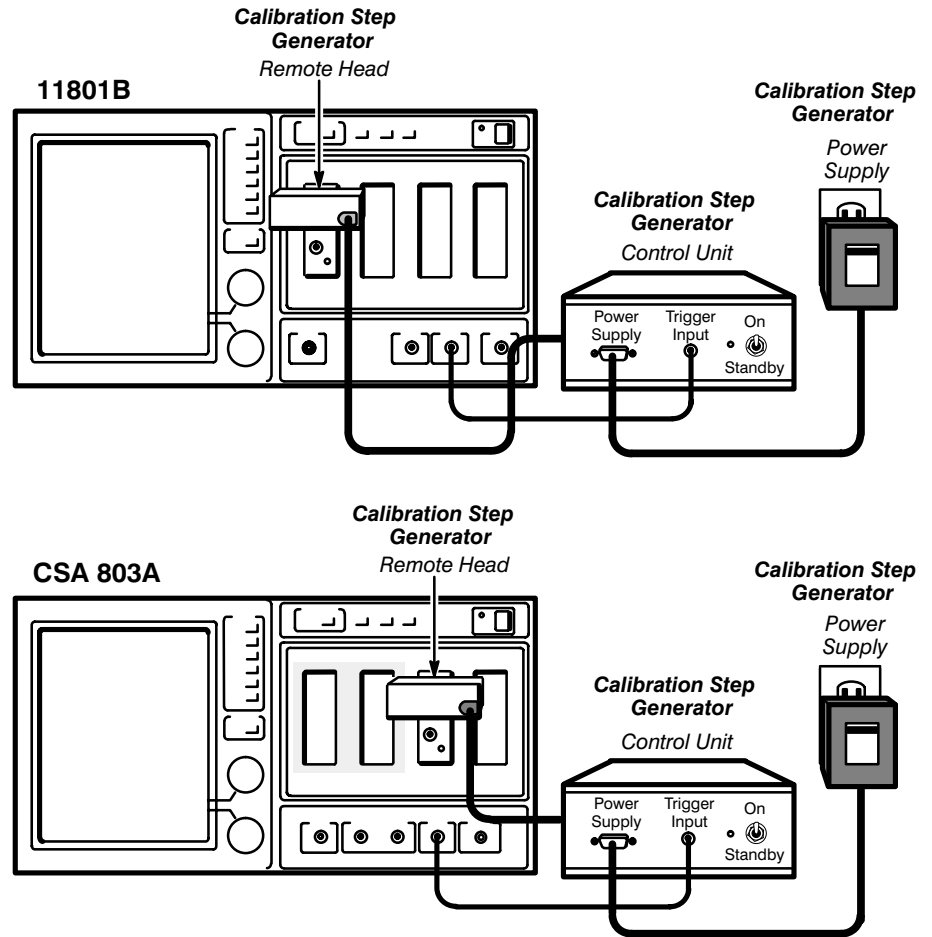

Procedure to Check Isolation Between Channels

- Step 1:** Initialize the instrument settings, then make the following settings in the order listed:

Sampling Head

CH 1 SELECT CHANNEL On/Off On

Instrument Mainframe

ENHANCED ACCURACY button (11801/2) press

UTILITY button (11801A/B, CSA 803 Series) press

Enhanced Accuracy (11801A/B, CSA 803 Series) touch

Calibrate All pop-up menu **Recall Defaults**

TRIGGER button press

Source **Internal Clock**

Calibration Step Generator

ON/STANDBY Switch ON

- Step 2:** Press the AUTOSET button.
- Step 3:** Touch the horizontal (↔) icon and then set the **Main Size** to 200 ps/div.
- Step 4:** Press the WAVEFORM button and then touch **Horizontal Desc.**
- Step 5:** Touch **Main Record Length** and then set **Main Record Len** to 1024 with the top knob.
- Step 6:** Touch **Acquire Desc** in the WAVEFORM major menu.
- Step 7:** Set **Average N** to **On** and then touch **Set Avg N** in the **Acquire Description** pop-up menu.
- Step 8:** Set **Average N** to 1024 with the top knob.
- Step 9:** Press the CH 2 SELECT CHANNEL button on the sampling head.
- Step 10:** Touch the vertical (↑↓) icon and then set the **Vert Size: M2** to 2 mV/div.
- Step 11:** Touch **Acquire Desc** in the WAVEFORM major menu and then set **Average N** to **On**.
- Step 12:** Wait until the **Acquire Desc** selector in the WAVEFORM major menu shows that 1024 averages have been completed.
- Step 13:** Touch the MEASURE button.
- Step 14:** Touch **Measurements** and then **Peak-Peak** in the **Measurements** pop-up menu.
- Step 15:** Record the CH 2 **Peak-Peak** measurement for later use.
- Step 16:** Press the CH 1 SELECT CHANNEL button.

- Step 17:** Touch **Measurements** and then **Peak-Peak** in the **Measurements** pop-up menu.
- Step 18:** Record the CH 1 **Peak-Peak** measurement for later use.
- Step 19:** *Check* that $(\text{CH 2 Peak-Peak}/\text{CH 1 Peak-Peak}) \times 100\% \leq 1\%$.
- Step 20:** Disconnect the calibration step generator remote head from CH 1 and the 50 Ω termination from CH 2. Connect the calibration step generator to CH 2, connect the 50 Ω termination to CH 1, and then press the CH 2 SELECT CHANNEL On/Off button.
- Step 21:** Press the AUTOSET button.
- Step 22:** Touch the horizontal (\leftrightarrow) icon and then set the **Main Size** to 200 ps/div.
- Step 23:** Press the CH 1 SELECT CHANNEL button.
- Step 24:** Press the AUTOSET button.
- Step 25:** Press WAVEFORM button.
- Step 26:** Wait until the **Acquire Desc** selector in the WAVEFORM major menu shows that 1024 averages have been completed.
- Step 27:** Press the MEASURE button.
- Step 28:** Touch **Measurements** and then **Peak-Peak** in the **Measurements** pop-up menu.
- Step 29:** Record the CH 1 **Peak-Peak** measurement for later use.
- Step 30:** Press the CH 2 SELECT CHANNEL button.
- Step 31:** Record the CH 2 **Peak-Peak** measurement for later use.
- Step 32:** *Check* that $(\text{CH 1 Peak-Peak}/\text{CH 2 Peak-Peak}) \times 100\% \leq 1\%$.

Part 10 Output Amplitude

This part shows the setup and lists the procedures to check the output amplitude.

Specifications

The specification for the output amplitude is 250 mV \pm 5 mV.

Setup to Check Output Amplitude

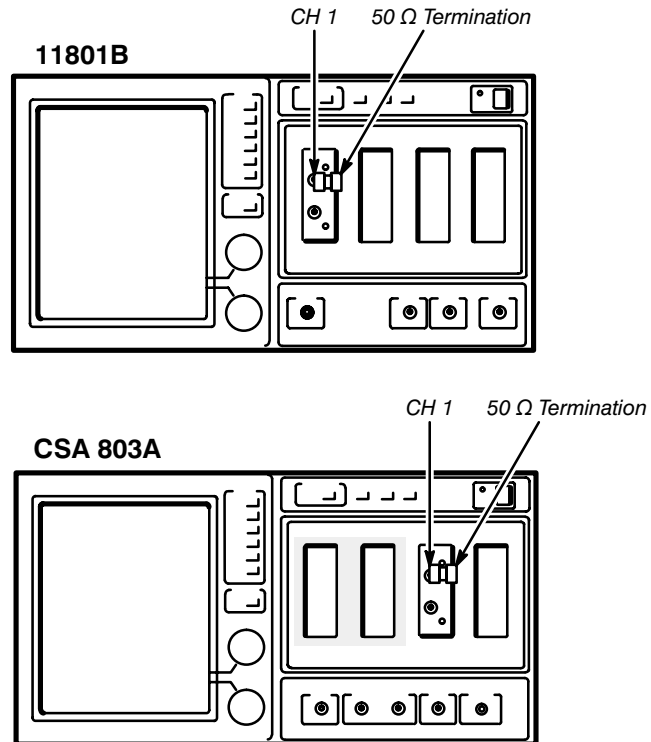

Procedure to Check Output Amplitude

- Step 1:** Initialize the instrument settings, then make the following settings in the order listed:

Sampling Head

CH 1 SELECT CHANNEL On/Off On

Instrument Mainframe

ENHANCED ACCURACY button (11801/2) press

UTILITY button (11801A/B, CSA 803 Series) press

Enhanced Accuracy (11801A/B, CSA 803 Series) touch

Calibrate All pop-up menu **Recall Defaults**

TRIGGER button press

Source **Internal Clock**

- Step 2:** Press the WAVEFORM button and then touch **Acquire Desc.**
- Step 3:** Set **Average N** to **On** and then touch **Set Avg N.**
- Step 4:** Set **Average N** to 64 with the top knob.
- Step 5:** Touch **Sampling Head Fnc's** in the WAVEFORM major menu and then set the CH1 **TDR** to **On.**
- Step 6:** Press the AUTOSET button.
- Step 7:** Touch the horizontal (↔) icon and then set the **Main Size** to 100 ns/div.
- Step 8:** Touch **Main Pos** and then **Min** in **Main Pos** pop-up menu.
- Step 9:** Press the UTILITY button and touch **Enhanced Accuracy** (11801A/B and CSA 803 Series) or press the ENHANCED ACCURACY button (11801/2).
- Step 10:** Touch **TDR Amplitude**, then **Automatic Calibrate**, and then **Proceed** in the **TDR Amplitude** pop-up menu.
- Step 11:** Touch **Cursors** at the top of the screen.
- Step 12:** Touch **Cursor Type** and then **Horizontal Bars.**
- Step 13:** Touch **Exit** to exit this menu.
- Step 14:** Set **Cursor 1** (top knob) to the average of the base of the pulse.
- Step 15:** Set **Cursor 2** to the average of the top of the pulse at 100 ns after the step.
- Step 16:** *Check* that ΔV is 250 mV \pm 5 mV.
- Step 17:** Press the WAVEFORM button.
- Step 18:** Touch **Sampling Head Fnc's** and then set the **TDR Polarity** to – in the **Sampling Head Functions** pop-up menu.
- Step 19:** Touch **Exit** to exit this menu.
- Step 20:** Touch the vertical (↑↓) icon and set the **Vert Offset: M1** so that the step is centered on the screen.
- Step 21:** Touch **Cursors** at the top of the screen.
- Step 22:** Set **Cursor 1** (top knob) to the average of the base of the pulse.
- Step 23:** Set **Cursor 2** to the average of the top of the pulse at 100 ns after the step.
- Step 24:** *Check* that ΔV is –250 mV \pm 5 mV.
- Step 25:** Repeat all of Part 10 for CH 2.

Part 11
TDR Aberrations

This part shows the setup and lists the procedures to check the TDR aberrations.

Specifications

The specifications for TDR aberrations are listed in Table 2-4, TDR Aberration Specifications.

Table 2-4: TDR Aberration Specifications

Time Difference from the Rising Edge of Waveform	Minimum Specification	Measurement Limit
0 to 300 ps		$-5\% \leq \text{aberration \%} \leq 15\%$
300 ps to 5 ns	$-3\% \leq \text{aberration \%} \leq 3\%$	
5 ns and up	$-1\% \leq \text{aberration \%} \leq 1\%$	
-10 ns to -20 ps	$-3\% \leq \text{aberration \%} \leq 3\%$	

Setup to Check TDR Aberrations

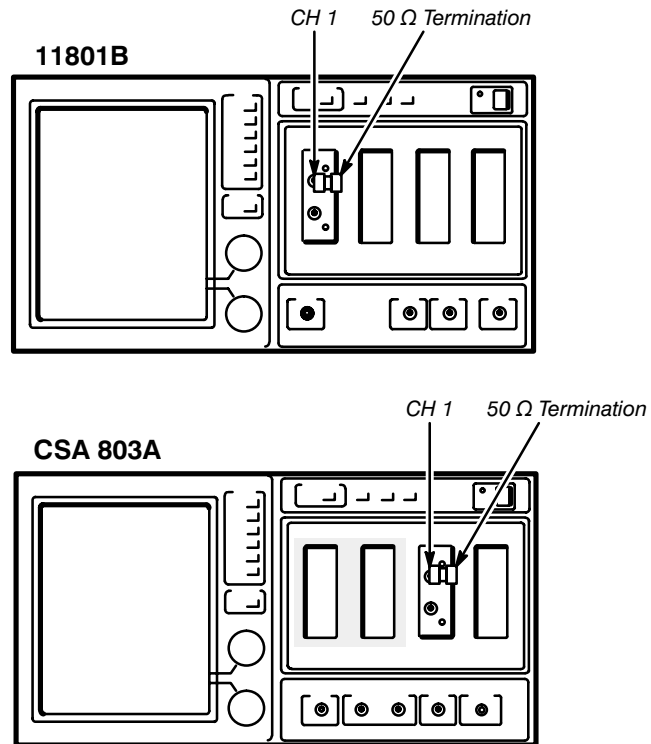

Procedure to Check TDR Aberrations

- Step 1:** Initialize the instrument settings, then make the following settings in the order listed:

Sampling Head

CH1 SELECT CHANNEL On/Off On

Instrument Mainframe

ENHANCED ACCURACY button (11801/2) press

UTILITY button (11801A/B, CSA 803 Series) press

Enhanced Accuracy (11801A/B, CSA 803 Series) touch

Calibrate All pop-up menu **Recall Defaults**

TRIGGER button press

Source **Internal Clock**

- Step 2:** Press the WAVEFORM button and then touch **Acquire Desc.**
- Step 3:** Set **Average N** to **On** and then touch **Set Avg N.**
- Step 4:** Set **Average N** to 128 with the top knob.
- Step 5:** Touch **Sampling Head Fnc's** in the WAVEFORM major menu and then set the CH 1 TDR to **On** in the **Sampling Head Functions** pop-up menu.

- Step 6:** Press the UTILITY button and touch **Enhanced Accuracy** (11801A/B and CSA 803 Series) or press the ENHANCED ACCURACY button (11801/2).
- Step 7:** Touch **TDR Amplitude** in the Enhanced Accuracy menu.
- Step 8:** Touch **Automatic Calibrate** and then **Proceed** in the **TDR Amplitude** pop-up menu.
- Step 9:** Press the AUTOSET button.
- Step 10:** Touch the horizontal (↔) icon and then set the **Main Size** to 100 ns/div.
- Step 11:** Set the **Main Pos** so that the rising edge of the step is at the left-most edge of the screen.
- Step 12:** Touch the vertical (↕) icon and then set the **Vert Offset:M1** so that the average of the top of the pulse at 100 ns after the step is at the horizontal centerline.
- Step 13:** Set the **Vert Size: M1** to 2 mV/div.
- Step 14:** Touch **Vert Offset: M1** and then **Fine** in the **Numeric Entry & Knob Res** pop-up menu.
- Step 15:** Set **Vert Offset: M1** so that the average of the top of the pulse at 100 ns after the step is at the horizontal centerline.
- Step 16:** Touch the horizontal (↔) icon and then set the **Main Size** to 10 ns/div.
- Step 17:** Set the **Main Pos** so that the rising edge of the step is at the left-most edge of the screen.
- Step 18:** *Check* that the magnitude of the maximum positive and negative aberrations that occur between 5 ns after the step and the right edge of the screen is ≤ 1.25 vertical divisions from the horizontal centerline (1% of the step amplitude).
- Step 19:** Set the **Main Size** to 500 ps/div and then set the **Main Pos** so that the rising edge of the step is at the left-most edge of the screen.
- Step 20:** *Check* that the magnitude of the maximum positive and negative aberrations that occur between 300 ps and 5 ns after the step is ≤ 3.75 vertical divisions from the horizontal centerline (3% of the step amplitude).
- Step 21:** Touch the horizontal (↔) icon and then set the **Main Size** to 500 ns/div.
- Step 22:** Touch the vertical (↕) icon and then set the **Vert Size:M1** to 10 mV/div.
- Step 23:** Set the **Vert Offset:M1** so that the average of the top of the pulse at 100 ns after the step is at the horizontal centerline.

- Step 24:** Touch the horizontal (↔) icon and then set the **Main Size** to 50 ps/div.
- Step 25:** Set the **Main Pos** so that the rising edge of the step is at the left-most edge of the screen.
- Step 26:** *Examine* that the magnitude of the maximum positive aberration that occurs in the first 300 ps after the 90% point of the step is ≤ 3.75 vertical divisions from the horizontal centerline (15% of the step amplitude).
- Step 27:** *Examine* that the magnitude of the maximum negative aberration that occurs in the first 300 ps after the 90% point of the step is ≤ 1.25 vertical divisions from the horizontal centerline (5% of the step amplitude).
- Step 28:** Set the **Main Size** to 2 ns/div.
- Step 29:** Touch the **Main Pos** selector and then **Set to Min** in the **Numeric Entry and Knob Res** pop-up menu.
- Step 30:** Touch the vertical (↓) icon and then set **Vert Offset:M1** so that the average of the bottom of the pulse at 10 ns before the step is at the horizontal centerline.
- Step 31:** Touch the horizontal (↔) icon and then set the **Main Size** to 1 ns/div.
- Step 32:** Set the **Main Pos** so that the rising edge of the step is at the right-most edge of the screen.
- Step 33:** *Check* that the magnitude of the maximum positive and negative aberrations that occur between 10 ns and 500 ps before the 10% point of the step is ≤ 1.0 vertical divisions from the horizontal centerline (4% of the step amplitude).
- Step 34:** Set the **Main Size** to 50 ps/div and then the **Main Pos** so that the rising edge of the step is at the right-most edge of the screen.
- Step 35:** *Check* that the magnitude of the maximum positive and negative aberrations that occur between 500 ps and 20 ps before the 10% point of the step is ≤ 1.0 vertical divisions from the horizontal centerline (4% of the step amplitude).
- Step 36:** Press the WAVEFORM button.
- Step 37:** Touch **Sampling Head Fnc's** and then set the **TDR Polarity** to – in the **Sampling Head Functions** pop-up menu.
- Step 38:** Repeat Steps 2 through 37 for CH 2.

Part 12 Reflected Rise Time

This part shows the setup and lists the procedures to check the reflected rise time.

Specifications

The specification for the reflected rise time is 35 ps.

Setup to Check Reflected Rise Time

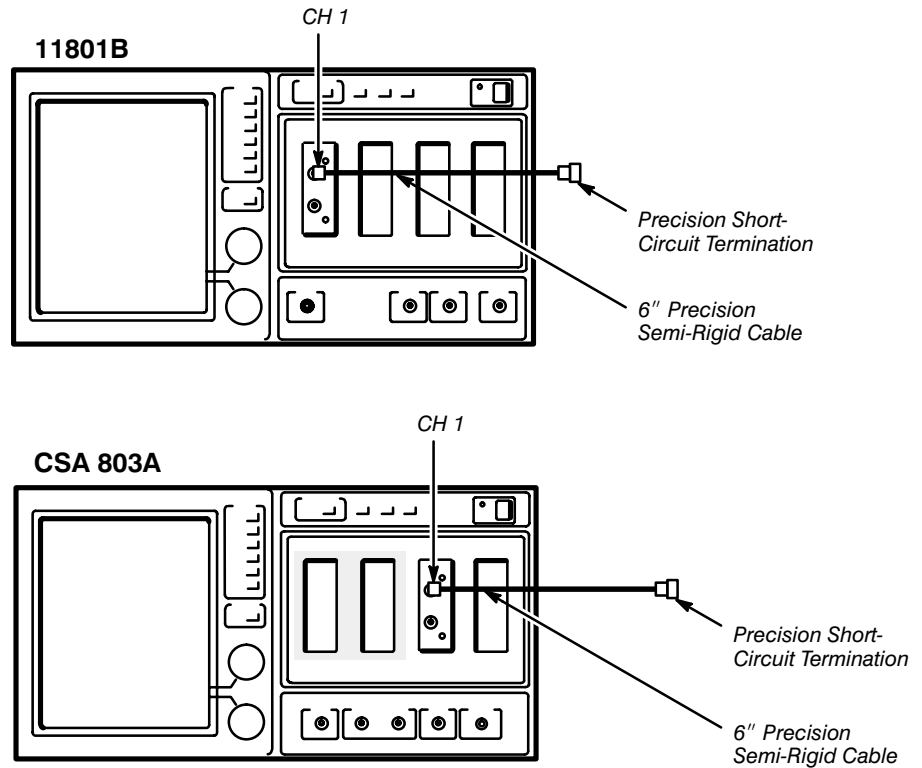

Procedure to Check Reflected Rise Time

- Step 1:** Initialize the instrument settings, then make the following settings in the order listed:

Sampling Head

CH 1 SELECT CHANNEL On/Off On

Instrument Mainframe

ENHANCED ACCURACY button (11801/2) press

UTILITY button (11801A/B, CSA 803 Series) press

Enhanced Accuracy (11801A/B, CSA 803 Series) touch

Calibrate All pop-up menu **Recall Defaults**

TRIGGER button press

Source **Internal Clock**

- Step 2:** Press the WAVEFORM button and then touch **Acquire Desc.**
- Step 3:** Set **Average N** to **On** and then touch **Set Avg N.**
- Step 4:** Set **Average N** to 128 with the top knob.
- Step 5:** Touch **Sampling Head Fnc's** in the WAVEFORM major menu and then set the CH1 **TDR** to **On.**
- Step 6:** Press the AUTOSET button.
- Step 7:** Touch the horizontal (↔) icon and then set the **Main Size** to 5 ns/div.
- Step 8:** Touch the **Main Pos** selector and then **Set to Min** in the **Numeric Entry and Knob Res** pop-up menu.
- Step 9:** Press the MEASURE button and then touch **Measurements.**
- Step 10:** Touch **Fall** in the **Measurements** pop-up menu and then **Fall** in the MEASURE major menu.
- Step 11:** Set **Tracking** to **Off** and then touch **Topline** in the **Fall** pop-up menu.
- Step 12:** Touch **Topline** in the MEASURE major menu and then **Fine** in the **Numeric Entry & Knob Res** pop-up menu.
- Step 13:** Set the **Topline** (top knob) so that it is 250 mV above the **Baseline.**
- Step 14:** Touch the horizontal (↔) icon and then set the **Main Pos** so that the reflection step is at the left-most edge of the screen.
- Step 15:** Set the **Main Size** to 20 ps/div and then the **Main Pos** to center reflection step on the screen.
- Step 16:** *Check* that **Fall** (reflected rise time) is ≤ 35 ps.
- Step 17:** Press the WAVEFORM button.
- Step 18:** Touch **Sampling Head Fnc's** and then set the **TDR Polarity** to – in the **Sampling Head Functions** pop-up menu.
- Step 19:** Touch **Exit.**
- Step 20:** Repeat Steps 6 through 16 for a negative TDR pulse. Note that all **Fall** selections must be replaced with **Rise** selections for a negative TDR pulse.
- Step 21:** Repeat Steps 2 through 20 for channel 2.

Checks and Adjustments

Maintenance

This section contains information for performing preventive maintenance and procedures for exchanging faulty sampling heads, removing and replacing sampling head internal circuitry, and changing the sampling head identification number.

Preventive Maintenance

Preventive maintenance performed regularly can prevent the breakdown and may improve reliability of the instrument and sampling head. The severity of the environment to which the sampling head is subjected determines the frequency of maintenance.

Exterior

Loose dust accumulated on the outside of the instrument or sampling head can be removed with a soft cloth or small brush. The brush is particularly useful for dislodging dirt in and around the sampling head connector and front panel switches.

Periodic Electrical Checks

To ensure accurate measurements, perform periodic electrical checks on the instrument and sampling head after each 2,000 hours of operation or every 24 months if used infrequently. Procedures to perform periodic electrical checks are given in Section 2, *Checks and Adjustments*.

Static-Sensitive Device Classification



Static discharge can damage any semiconductor component in the instrument or sampling head. To prevent damage from electrostatic discharge, follow all precautions listed in this section.

The instrument and sampling head contain electrical components that are susceptible to damage from static discharge. Table 3-1 gives relative susceptibility of various classes of semiconductors. Static voltages of 1 kV to 30 kV are common in unprotected environments.

Observe the following precautions to avoid damage:

- Step 1:** Minimize handling of static-sensitive components.
- Step 2:** Transport and store the sampling heads in their original containers on a metal surface or conductive foam. Transport the sampling heads with short-circuit terminations on the inputs. Label any package that contains static-sensitive assemblies or components.
- Step 3:** Discharge the static voltage from your body by wearing a wrist strap while handling these components. Service of static-sensitive assemblies or components should be performed only at a static-free work station by qualified service personnel. We recommend the use of the static control mat and wrist strap.
- Step 4:** Allow nothing capable of generating or holding a static charge on your work station surface.
- Step 5:** Keep the component leads shorted together whenever possible.
- Step 6:** Pick up components by the body, never by the leads.
- Step 7:** Do not slide the components over any surface.
- Step 8:** Avoid handling components in areas that have a floor or work-surface covering capable of generating a static charge.

Table 3-1: Relative Susceptibility to Electrostatic Discharge (ESD)

Semiconductor Classes	Relative Susceptibility Levels¹
MOS or CMOS microcircuits or discrete circuits, or linear microcircuits with MOS inputs (most sensitive)	1
ECL	2
Schottky signal diodes	3
Schottky TTL	4
High-frequency bipolar transistors	5
JFET	6
Linear microcircuits	7
Low-power Schottky TTL	8
TTL (least sensitive)	9

¹Voltage equivalent for levels (voltage discharged from a 100 pF capacitor through resistance of 100 Ω):

1 = 100 to 500 V

2 = 200 to 500 V

3 = 250 V

4 = 500 V

5 = 400 to 600 V

6 = 600 to 800 V

7 = 400 to 1000 V (est.)

8 = 900 V

9 = 1200 V

Exchanging Sampling Heads

If a sampling head fails any of the procedures in Section 2, *Checks and Adjustments*, of this manual, then it may be exchanged for a new sampling head.

Sampling head exchanges can be made with either your local Tektronix service center or the Central Tektronix Exchange Center in Beaverton, Oregon.

For more information on exchanging your sampling head, refer to Module Exchange in Section 5, *Replaceable Parts*.

Removing and Replacing the Sampling Head Internal Circuitry



To avoid damage to the sampling head, set the instrument's ON/STANDBY switch to STANDBY and remove the sampling head from the instrument before removing or replacing the internal circuitry.

Perform the following procedures to remove and replace the internal circuitry in the sampling head.

- Step 1:** Remove the SELECT CHANNEL On/Off button by gently pulling on the plastic knob with small needle-nose pliers.
- Step 2:** Remove the three small Pozidrive screws on each side of the sampling head's casing (see Figure 3-1).
- Step 3:** Remove the front panel and the casing from the internal circuitry.
- Step 4:** Install the internal circuitry into the gray shipping casing.
- Step 5:** Return the internal circuitry (the circuit board and attached carrier) for sampling head exchange or repair.
- Step 6:** To replace the internal circuitry, follow the removal procedures in reverse order.

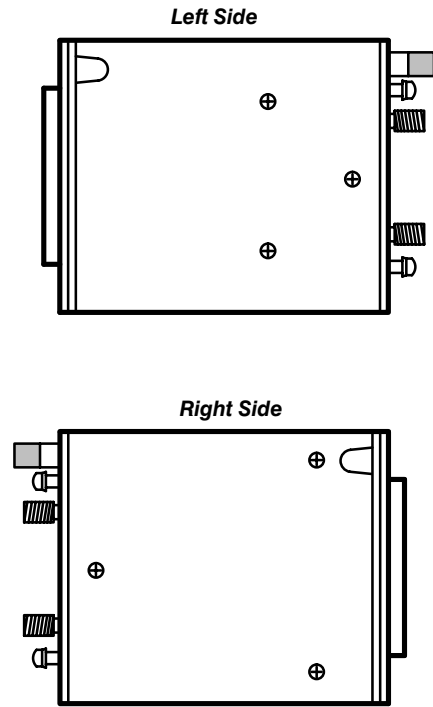

Figure 3-1: Sampling Head Screw Locations

Changing the Sampling Head Identification Number

The following procedure allows you to change the sampling head identification number to fit the requirements of your application.

The following equipment, in addition to an 11800 Series or CSA 803 Series instrument and an SD-24 TDR/Sampling Head, is necessary to perform this procedure:

- IBM PC or any other compatible PC that has MS DOS and an RS-232-C serial port configured for COM1
- a serial cable

Procedure to Change the Sampling Head Identification Number:

- Step 1:** With the instrument's PRINCIPAL POWER SWITCH set to OFF, install one of the short-circuit jumpers across the two J860 pins on the A5 Time Base/Controller Board. These short-circuit jumpers are located on several jumper pins on the A5 Time Base/Controller board. This board is located on the bottom of the instrument and can be accessed once the bottom panel is removed. Refer to the *Maintenance* section in the *Service Manual* for your instrument for more information on accessing this board. See Figure 3-2 for the location of jumper J860.

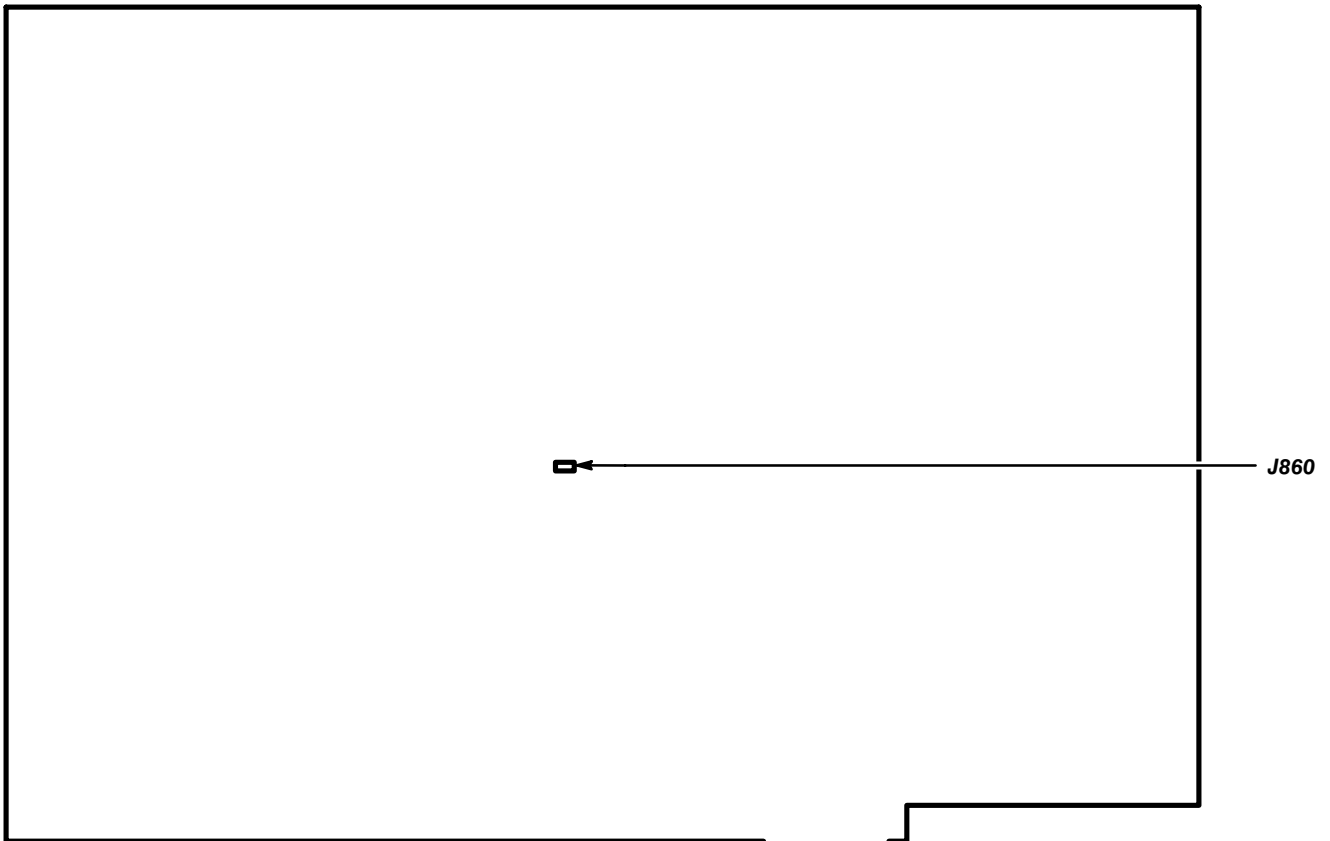

Figure 3-2: A5 Time Base/Controller Board Jumper Location

- Step 2:** Boot up the PC with **MS DOS** operating.
- Step 3:** Connect the serial cable to the instrument's RS-232-C port located at the rear of the instrument. Connect the other end of the cable to the COM1 port on the PC.
- Step 4:** Install the SD-24 TDR/Sampling Head in any sampling head compartment in the instrument.
- Step 5:** Set the PRINCIPAL POWER SWITCH to ON and the ON/STANDBY switch to ON.
- Step 6:** After the diagnostics are complete, press the UTILITY button and then touch **RS-232 Parameters**.
- Step 7:** Set the **Baud Rate** to **4800 Bd**, the **Parity** to **none**, and the **Stop Bits** to **1** in the **RS-232 Parameters** pop-up menu.
- Step 8:** Insert the Sampling Head Utility Software floppy disk (provided in this manual) into the "A" drive of the system controller.
- Step 9:** On the PC, type **a:** and then press the return or enter key.
- Step 10:** Type **id** and then press the return or enter key.

The PC then displays the following message:

Make sure 11800 RS232 port is set up as follows:

Baud Rate	4800
Parity	none
Stop bits	1

Enter mainframe head number [1..4]

NOTE

When entering the sampling head number, the 11802 Oscilloscope and the CSA 803 Series Communications Signal Analyzers have only head number 1 and head number 2. The 11801 Series Oscilloscopes have head number 1 through head number 4. The head numbers correspond to the sampling head compartments and are in ascending order (reading from left to right).

- Step 11:** To enter the sampling head number, type in the correct sampling head number and then press the return or enter key.

The PC then displays the following message:

Current ID number is: "XXXXXXXX"
Enter new ID number (8 characters max):

NOTE

The X's between the quotes represent the current ID number. Eight is the maximum number of digits allowed and one is the minimum. Any character is allowed, except a space () character.

- Step 12:** Enter one to eight characters for the new identification number.

The instrument will then flash the message:

Change in channel M × configuration

four times at the top of the screen.

- Step 13:** Set the ON/STANDBY switch to STANDBY, and then switch it back to ON.

- Step 14:** To verify the new identification number, press the UTILITY button, and then touch **Identify**.

The new identification number now appears under **Mainframe Sampling Heads** in the **System Identification** pop-up menu.

- Step 15:** Remove the jumper that was installed on J860 in Step 1.

Theory of Operation

The SD-24 TDR/Sampling Head is a two-channel, 17.5 ps rise time sampling head. Each channel is also capable of generating its own Time Domain Reflectometry (TDR) output pulse.

When used in the acquisition mode (that is, with the TDR step generator turned off) each channel functions as a normal sampling input. Both channels are strobed simultaneously from a single strobe generator contained within the sampling head, so time coincidence between the two channels is stable. Loop gain and zeroing can be calibrated electronically by the instrument with some user interaction.

In the TDR mode, a fast rise time step is generated internally for each channel and applied to the input signal path for that channel. The acquisition portion of the sampling head is still functional for monitoring the primary pulse and its reflected components. The sampling head provides two self-contained TDR channels. The polarity of the output pulse can be selected independently for each channel. This allows differential or common mode testing of two coupled lines as well as independent testing of isolated lines.

System Functional Overview

This section describes and illustrates the major functional blocks of the SD-24 TDR/Sampling Head (see Figure 4-1).

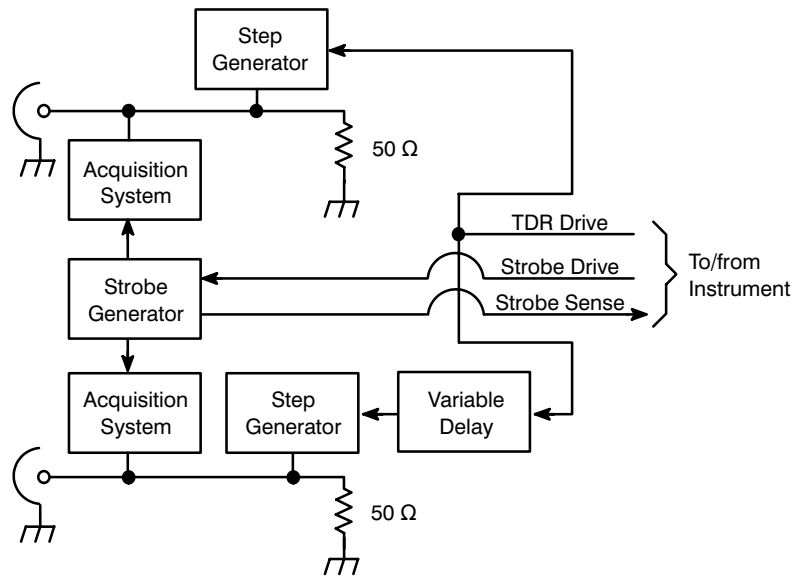

Figure 4-1: SD-24 TDR/Sampling Head Block Diagram

The SD-24 TDR/Sampling Head has two independent channels; each has its own acquisition and step generation circuitry. The strobe drive signal from the instrument controls the timing of the strobe assertion to each acquisition system. The strobe generator in the sampling head is common to both channels, guaranteeing sampling coincidence between the two channels.

The step generators can assert a negative-going or positive-going step independently. Using both channels, you can perform differential and common mode TDR and two-port, time-domain network analysis.

The TDR drive pulse triggers the internal step generators to assert either the positive or negative transition of the TDR step signal.

The strobe sense signal is a part of the strobe signal returned to the instrument. The instrument monitors the time duration of the strobe drive/strobe sense loop and adjusts a delay line inside the instrument to maintain correct strobe timing.

The acquisition rise time is 17.5 ps or less. The displayed TDR incident rise time is 28 ps or less. The combined acquisition rise time is 28 ps or less. To ensure proper timing between the two step outputs, the second channel is equipped with a variable delay.

TDR Step Generation

The step generator circuitry consists fundamentally of an adjustable current source and a diode switch. Initially, before the step, the diode switch is biased to conduct current to the output. When the diode switch opens, the step occurs. Figure 4-2, a simplified diagram, shows the switch and the current source.

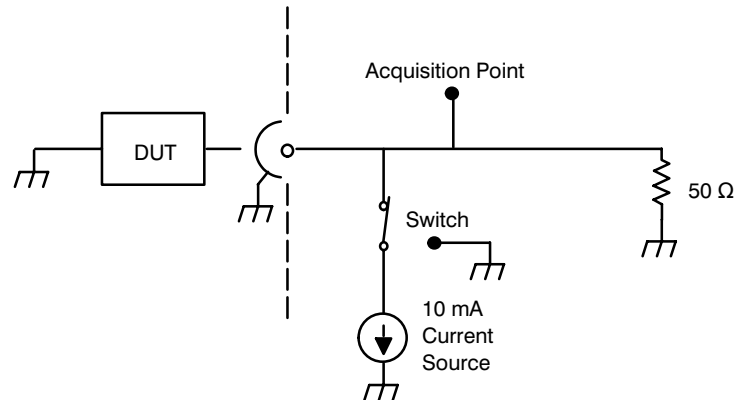

Figure 4-2: Step Generator Simplified Schematic Diagram

Because of the architecture of the step generator, the output voltage of the step depends on the DC resistance to ground of the device under test (DUT). The following sections describe the operation with a short circuit, an open circuit, and a 50 Ω load.

Operation With a Short Circuit

Initially, the diode switch is conducting -10 mA. Since the step generator output is initially shorted, the resistance to ground is 0 Ω and the output voltage is 0 V (see 1 in Figure 4-3).

When the diode switch opens (reverse-biased), apparent resistance to ground at the acquisition point (and at the channel connector) is 25 Ω because the internal termination resistance is 50 Ω and the connector impedance is 50 Ω. The voltage at the acquisition point rises to $+250$ mV (see 2 in Figure 4-3).

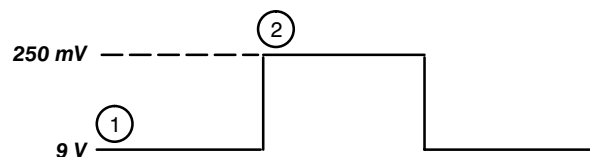

Figure 4-3: Step Generator With a Shorted Output

The transition propagates to the short in the DUT and is negatively reflected back to the acquisition point, cancelling the transition. The time displayed from the first transition to the second transition is the propagation time from the acquisition point to the short in the DUT and back.

Operation With a 50 Ω Load

Initially, the diode switch is conducting. Since the step generator output is connected to a 50 Ω load, the resistance to ground at the acquisition point is 25 Ω because of the internal 50 Ω impedance. The 10 mA current source places -250 mV at the acquisition point (see 1 in Figure 4-4).

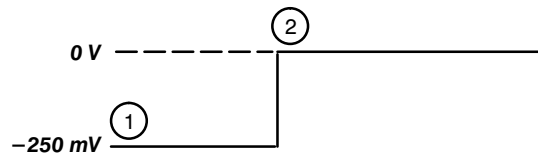

Figure 4-4: Step Generation With a 50 Ω Load

When the diode switch opens (reverse-biased), the return path to ground is broken and the acquisition point rises to 0 V. The matched impedance allows the acquisition point to remain at 0 V (see 2 in Figure 4-4).

Operation With an Open Circuit

Initially, the diode switch is conducting. Since the step generator output is open, the resistance to ground at the acquisition point is 50 Ω because of the internal 50 Ω impedance. The -10 mA current source places -500 mV at the acquisition point, as a starting condition (see 1 in Figure 4-5).

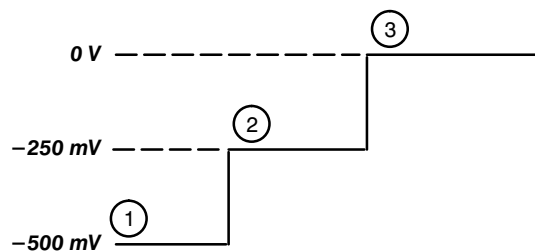

Figure 4-5: Step Generation With an Open Circuit

When the diode switch opens (reverse-biased), apparent resistance to ground at the acquisition point (and at the channel connector) is 25 Ω because the internal circuit impedance is 50 Ω and the connector impedance is 50 Ω . This causes the acquisition point to rise to -250 mV (see 2 in Figure 4-5).

The transition propagates to the open in the DUT and is reflected back to the acquisition point, causing the voltage at the acquisition point to rise to 0 V (see 3 in Figure 4-5). At the acquisition point, the time displayed from the first step to the second step is the propagation time from the acquisition point to the open in the device under test and back.

TDR Amplitude

Using the SD-24 TDR/Sampling Head's internal step generator with the acquisition channel, you can perform TDR measurements. You can also adjust the amplitude of the TDR step.

The TDR step amplitude setting is highly stable and insensitive to temperature variations. Usually, it is not necessary to adjust this parameter very frequently.

The SD-24 TDR/Sampling Head contains nonvolatile memory that stores two values, the factory default value and the user value, for the TDR amplitude adjustment.

Loop Gain

Loop gain determines the sampling head's ability to accurately follow an input voltage change that occurs between two adjacent samples. The accuracy with which the sampling head output follows the input signal is termed the dot transient response.

When loop gain is unity (1), the value of the first sample acquired after an input voltage change accurately reflects the voltage change, indicating a good dot transient response (see Figure 4-6).

If loop gain is adjusted too low, then the value of the first sample acquired after an input voltage change will be between the value of the last sample and the new voltage.

If loop gain is adjusted too high, then the value of the first sample acquired after the input voltage change will be greater than the new voltage level.

Figure 4-6 shows the displayed trace results for the three loop gain conditions.

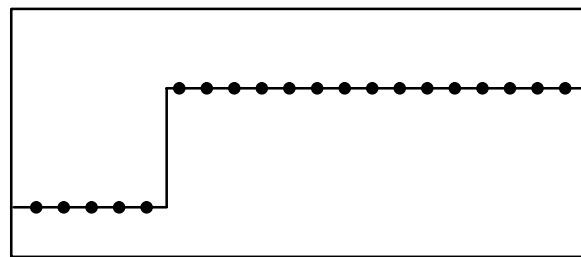

Unity Loop Gain

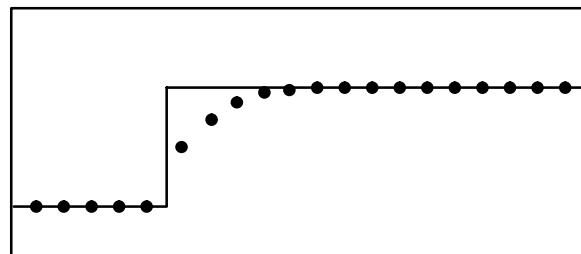

Insufficient Loop Gain

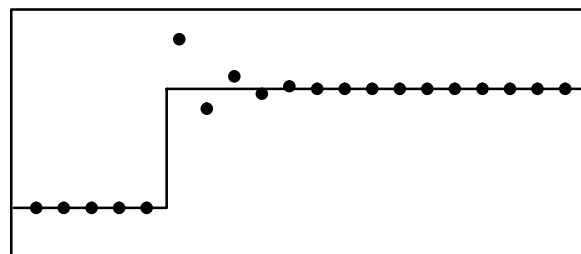

Excessive Loop Gain

Figure 4-6: Displayed Trace With Three Loop Gain Settings

Offset Null

The offset null adjustment removes unwanted DC offset that may be present in the sampling head. This adjustment effectively zeroes the sampling head so that an input signal with 0 V of amplitude delivers a 0 V output.

If offset null is not adjusted correctly, then measurements taken at the instrument will be incorrect. The absolute voltage values for any cursors displayed on the trace will be incorrect as well.

Replaceable Parts

This section contains a list of the components that are replaceable for the SD-24 TDR/Sampling Head. As described below, use this list to identify and order replacement parts.

Parts Ordering Information

Replacement parts are available from or through your local Tektronix, Inc. service center or representative.

Changes to Tektronix instruments are sometimes made to accommodate improved components as they become available and to give you the benefit of the latest circuit improvements. Therefore, when ordering parts, it is important to include the following information in your order:

- Part number
- Instrument type or model number
- Instrument serial number
- Instrument modification number, if applicable

If a part you order has been replaced with a different or improved part, your local Tektronix service center or representative will contact you concerning any change in the part number.

Change information, if any, is located at the rear of this manual.

Module Replacement

The SD-24 TDR/Sampling Head is serviced by module replacement so there are three options you should consider:

- **Module Exchange** — In some cases you may exchange your module for a remanufactured module. These modules cost significantly less than new modules and meet the same factory specifications. For more information about the module exchange program, call 1-800-TEKWIDE, ext. 6630.
- **Module Repair** — You may ship your module to us for repair, after which we will return it to you.
- **New Modules** — You may purchase new replacement modules in the same way as other replacement parts.

Using the Replaceable Parts List

The tabular information in the Replaceable Parts List is arranged for quick retrieval. Understanding the structure and features of the list will help you find the all the information you need for ordering replacement parts.

Item Names

In the Replaceable Parts List, an Item Name is separated from the description by a colon (:). Because of space limitations, an Item Name may sometimes appear as incomplete. For further Item Name identification, U.S. Federal Cataloging Handbook H6-1 can be used where possible.

Abbreviations

Abbreviations conform to American National Standards Institute (ANSI) standard Y1.1.

CROSS INDEX – MFR. CODE NUMBER TO MANUFACTURER

Mfr. Code	Manufacturer	Address	City, State, Zip Code
TK0435	LEWIS SCREW CO	4300 S RACINE AVE	CHICAGO IL 60609-3320
TK1163	POLYCAST INC	9898 SW TIGARD ST	TIGARD OR 97223
0GZV8	HUBER AND SUHNER INC	500 WEST CUMMINGS PARK	WOBURN MA 01801
OKB05	NORTH STAR NAMEPLATE	1281 -S NE 25TH	HILLSBORO OR 97124
02660	AMPHENOL CORP INDUSTRIAL TECHNOLOGY DIVISION (ITD)	720 SHERMAN AVENUE PO BOX 4340	HAMDEN CT 06514
13047	MAURY MICROWAVE CORP	8610 HELMS AVE	CUCAMONGA CA 91730-4520
20944	WILTRON CO	490 JARVIS DR	MORGAN HILL CA 95037-2809
80009	TEKTRONIX INC	14150 SW KARL BRAUN DR PO BOX 500	BEAVERTON OR 97077-0001

Replaceable Parts

Fig. & Index No.	Tektronix Part No.	Serial No.		Qty	Name & Description	Mfr. Code	Mfr. Part No.
		Effective	Dscont				
5-1-1	366-0673-00			2	KNOB:0.096 ID X 0.24 OD X 0.299H	TK1163	ORDER BY DESC
-2	334-7070-00			1	LABEL:FRONT PANEL	0KB05	ORDER BY DESC
-3	211-0088-00			3	SCREW,MACHINE:2-56 X 0.281,FLH,82 DEG,STL	TK0435	ORDER BY DESC
-4	333-3427-01			1	PANEL,FRONT:SD24	80009	ORDER BY DESC
-5	380-0831-00			1	HSG,SMPLG HEAD:ALUMINUM	TK1465	ORDER BY DESC
-6	211-0087-01			3	SCREW,MACHINE:2-56 X 0.188,FLH,82 DEG,STL	TK0435	ORDER BY DESC
	657-0057-50	B010100	B020651	1	MODULAR KIT:SD24,EXCHANGE MODULAR ASSY	80009	657005750
	657-0057-51	B020652		1	MODULAR ASSY:SD24,FIELD REPLACEABLE UNIT (EXCHANGE ITEM)	80009	657005751
	334-7638-00			2	MARKER,IDENT:MKD STATIC WARNING	0KB05	ORDER BY DESC
STANDARD ACCESSORIES							
	015-1020-00			2	TERM,COAXIAL:SHORT CIRCUIT,SMA	0GZV8	64SMA-50-0-1
	070-7052-01			1	MANUAL,TECH:USER,SD24	80009	070705201
	070-7053-01			1	MANUAL,TECH:SERVICE,SD24	80009	070705301
OPTIONAL ACCESSORIES							
	011-0148-00			1	TERM,COAX:50+/-0.1 OHM,PRECISION 3.5MM	20944	28K50
	011-0149-00			1	TERM,COAX:50 OHM,26.5GHZ,PRECISION 3.5MM	20944	28KF50
	011-0150-00			1	TERM,COAX:SHORT,34GHZ,PRECISION 3.5MM	13047	360D
	011-0151-00			1	TERM,COAX:SHORTING,34GHZ,3.5MM,MALE	13047	360B
	011-0152-00			1	ATTEN,COAX:50 OHM,6DB,40.0GHZ,2.92MM	20944	41KC-6
	011-0153-00			1	ATTEN,COAX:50 OHM,20DB,2.92MM,MALE	20944	41KC-20
	015-0549-00			1	CONN,RF ADPT:SMA,;50 OHM,MALE TO FEMALE	0GZV8	33SMA-50-0-1
	015-0550-00			1	ADPTR,RF,PRCN::3.5MM,FEMALE TO FEMALE	20944	33SFSF50
	015-0551-00			1	ADPTR,RF,PRCN::3.5MM,MALE TO MALE	20944	33SS50
	015-0552-00			1	ADPTR,APC,ELEC:3.5MM,MALE TO FEMALE	02660	131-7053
	015-0553-00			1	ADPTR,SMA,ELEC:MALE TO FEMALE	98291	50-674-6324-99
	015-0557-00			1	POWER DIVIDER:DC-40 GHZ,2.92MM	20944	K240C
	015-0558-00			1	TERMINATOR,ELEC:10 X 20DB,DC TO 10 GHZ	66598	523-150
	015-0561-00			1	CABLE,DLY,COAX:50 OHM,4NS,W/CONN,MALE	0GZV8	SF104PE,920MM,2
	015-0562-00			1	CABLE,DLY,COAX:50 OHM,1NS,W/CONN,MALE	0GZV8	SF104PE,230MM,2
	015-0563-00			1	CABLE,DLY,COAX:50 OHM,2NS,W/CONN	0GZV8	SF104PE,460MM,2
	015-0564-00			1	CABLE,DLY,COAX:50 OHM,500PS,W/CONN	20944	K120-6
	020-1693-00			1	COMPONENT KIT:SMA KIT	80009	020169300
	067-1338-00			1	FIXTURE,CAL:SAMPLING HEAD CAL UNIT (STANDARD)	80009	067133800
	067-1338-01			1	FIXTURE,CAL:SAMPLING HEAD CAL UNIT (EUROPEAN)	80009	067133801
	067-1338-02			1	FIXTURE,CAL:SAMPLING HEAD CAL UNIT (UNITED KINGDOM)	80009	067133802
	067-1338-03			1	FIXTURE,CAL:SAMPLING HEAD CAL UNIT (AUSTRALIAN)	80009	067133803
	067-1338-05			1	FIXTURE,CAL:SAMPLING HEAD CAL UNIT (SWISS)	80009	067133805
	067-1338-06			1	FIXTURE,CAL:SAMPLING HEAD CAL UNIT (JAPANESE)	80009	067133806

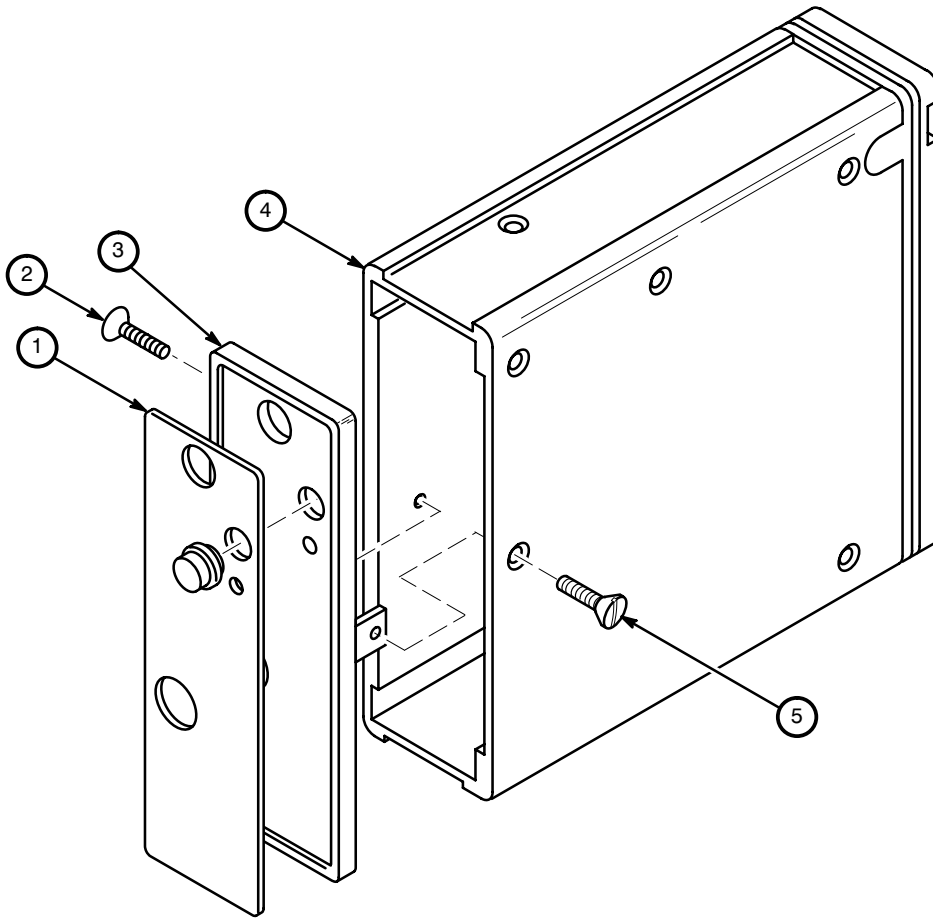

Figure 5-1: Exploded View of the SD-24 Sampling Head

